



Worcester Controls Three Piece Ball Valves

Series 44, Series 45, Series 59



Experience In Motion



Series 44 Ball Valves

A quantum advance in ball valve durability, cycle life, leak tightness and automation.

Flowserve Worcester Controls Series 44 three-piece ball valves, for many years the most respected ball valve design in the industry, are now better than ever. A major research, design, and testing program brings you a new valve, designed to ANSI B16.34 specifications with advanced seal technology and body mount bracket design. This means a very strong, tough valve that can handle pressure and unforeseen piping strains with a stem seal that extends operational cycle life and a standardized overall design that keeps parts inventory to a minimum. Then there's documentation. B16.34 means complete traceability of assembly and testing procedures, heat codes, and foundry identification. Full Certified Material Test Reports (CMTRs) on pressure vessel parts are optionally available. Valve identification is provided on a stainless steel nameplate meeting MSS SP-25.

High Performance

An improved stem seal design, consisting of live-loaded PEEK and Polyfill® thrust bearings and seals, significantly increases valve cycle life over conventional ball valves and extends time between adjustments. In manual valves, the two spring washers are compressed by two retaining nuts. A single Nylon-insert locking nut and four spring washers are used on automated valves.

Stem Seals

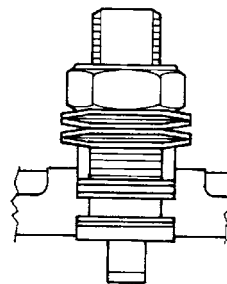

Automated Valve

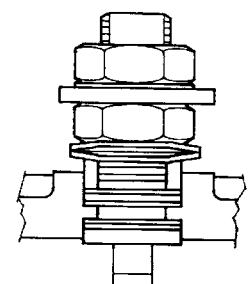

Manual Valve

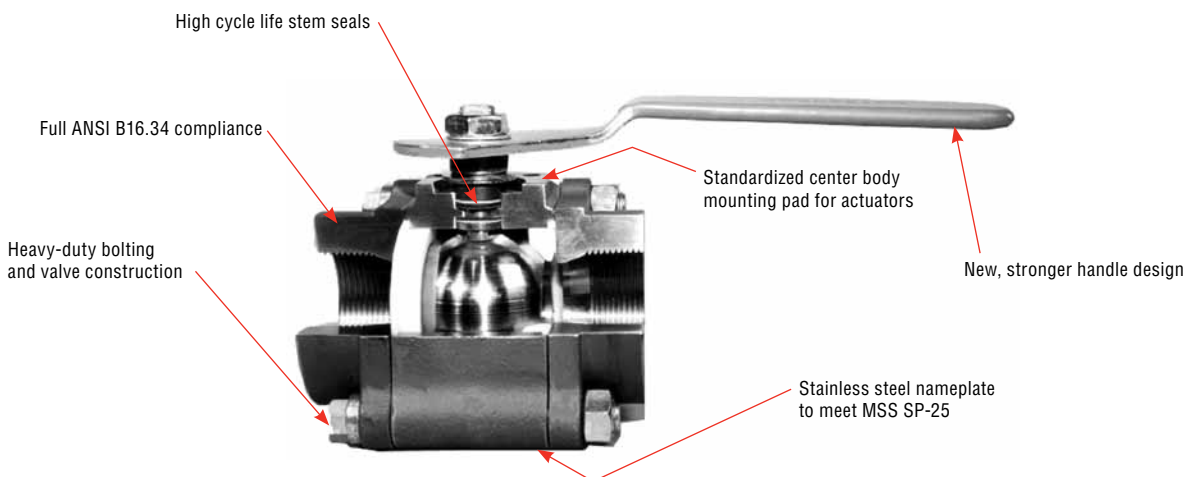

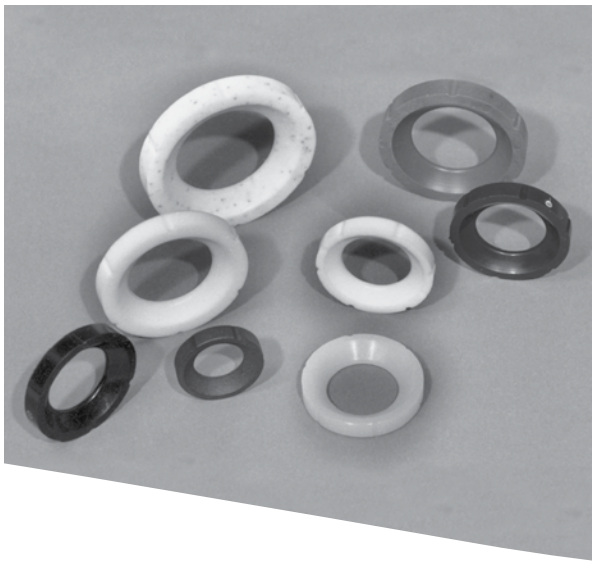

The range of Worcester Controls' seat materials is unmatched and includes Buna, Neoprene, TFE, Reinforced TFE, Polyfill, Lubetal™, High-per Fill and UHMWPE.

Body-Mounted Actuator Design

Actuators for Worcester Controls Series 44 three-piece valves are mounted on rigid, precisely machined, box-style brackets bolted to the valve center section. This brings a number of advantages to the valve user:

- Actuator loads are on the valve body;
- Actuators and brackets can be removed for service without affecting valve or piping integrity;
- Easy access for stem seal adjustment;
- Inventory simplification. Mounting brackets are common to three-piece and equivalent flanged valves.



1/4"-1"

1 1/4"-2"

Multiple End Connections, Seat and Seal Combinations

Available through a nationwide network of distributors, Worcester Controls Series 44 quarter-turn ball valves and replacement parts are stocked and ready to be adapted to each individual application.

Features that make this tough, reliable ball valve so unique include tight shutoff, smooth two-way flow, advanced seat materials, a variety of interchangeable end connections, swing away three-piece construction, and a design ready for automation.

A variety of pipe ends, including socket weld, screw ends, butt weld or any combination of these, enables Series 44 valves to be adapted to fit standard and more unusual piping situations. Series 44 (V67) valves can also be welded in place, fully assembled with "G" graphite-coated 316 stainless steel body seals and reinforced TFE, Polyfill, or High-per Fill® seats.

The range of Worcester Controls' seat materials is unmatched and includes Buna, Neoprene, TFE, Reinforced TFE, Polyfill, Lubetal™, High-per Fill and UHMWPE. These seats easily handle a great majority of industrial fluids with temperatures from -50°F to +600°F including steam, chemicals, petrochemicals, petroleum products, caustics and fluids containing solids, fibrous or abrasive materials.

Swing-Out Design For Easy Maintenance



The Series 44 is especially well suited for use in piping systems where line breaks are required and total entry into the line is necessary. The center section can swing out, eliminating the need to cut a valve out of line and having to replace both the valve and the pipe. Because of this design, the seats, seals and ball can all be replaced quickly and easily without disturbing pipe alignment. Acting as both a valve and a union, the Series 44 eliminates the need for a separate union.

Tight Shutoff and Bidirectional Sealing

Worchester's three-piece ball valves are designed to seal bidirectionally against resilient seats. Relief slots assist in downstream sealing and reduce torque. The ball is forced to the downstream side under pressure and forced against the downstream seat to effect and maintain a seal. Consequently, the valve will give bubble-tight shutoff throughout a long service life even with seats of relatively non-resilient materials such as TFE or Polyfill. The seats are also designed to perform a wiping action during each cycle—cleaning foreign materials off both the seat and ball, assuring leak-tight sealing.

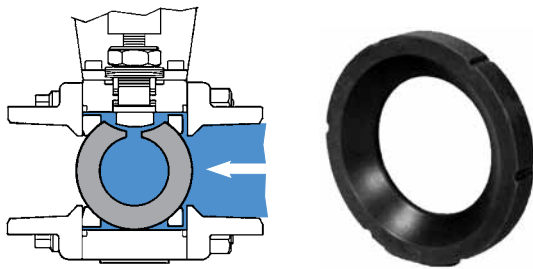

Valve shown in closed position, full pressure

The downstream sealing of Worchester Controls' three-piece valves overcomes the two most common difficulties in the use of conventional ball valves: seat damage and high operating torque. A hole in the stem slot prevents any possibility of damage due to trapped cavity pressure when the ball is open. An optional ball cavity vent is available for specific applications. The Flowserve Worchester Controls design results in smoother, more efficient valve operation.

Special Service and Approvals

Underwriter Laboratory Listed

- Flammable liquid shutoff (YRBX)
- Gas shutoff (YRPV)
- LP gas shutoff (YSDT)
- Anhydrous ammonia shutoff (YQAR)
- Compressed gas shutoff, including oxygen (YQNZ)
- Trim and Drain Valves (VQGU)

Factory Mutual Approval for:

- Gas and Oil Safety Shutoff

Other Approvals

- U.S.C.G. – United States Coast Guard
- U.S.D.A. – United States Dept. of Agriculture

Consult Flowserve when ordering approved valves.

Seat Pressure/Temperature Ratings

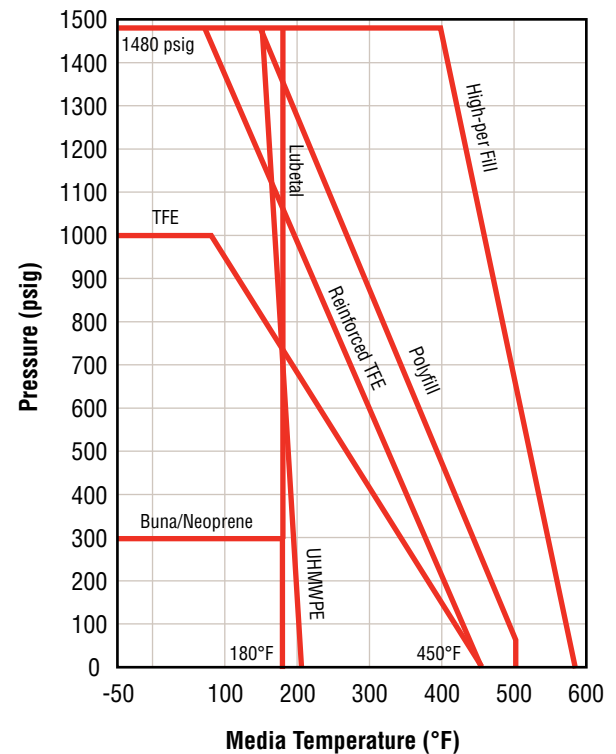

• Maximum Temperature for Seals:

UHMWPE:	200°F	Neoprene:	250°F
Buna:	250°F	EPR:	350°F
TFE:	400°F	Viton:	450°F
TFE coated		Graphite coated	
Stainless Steel:	650°F	Stainless Steel:	1000°F

- “R” (Reinforced TFE) and “P” (Polyfill) seats may be used up to a maximum of 1480 psig as shown. Some decrease in optimum seat life may be expected in some cases above 1000 psig.
- TFE body seals are limited to 200°F temperature swings. (Thermal cycles)
- For high-pressure applications to 3000 psi, Flowserve recommends the Series 4 three-piece valves with Lubetal seats. Refer to brochure WCABR1009. For pressures to 5000 psi, specify the Series H44 Dyn-O-Miser® valve with Lubetal or High-per Fill seats. Refer to brochure WCABR1048.

▲ CAUTION: For high pressure media that are highly flammable, explosive or toxic, consult Flowserve.

NOTE: Standard Worcester Controls valves are assembled with silicon-based break-in lubricant. For other options, consult your distributor or Flowserve.

Operating Torque for Automated Valves

Valve Torque:

Before the actuator can be sized for any given valve application, the operating torque required for the valve must be determined. The operating torque of the ball valve is influenced by a number of factors—some are design- and materials-related, others are application- (service conditions) related. Design-related factors include the type and material of the valve seats, while application factors include system pressure, media and frequency of operation.

For complete valve operating torque data, refer to Worcester’s Actuator Sizing Manual (WCASS0001). This eight-page publication explains the concept of valve torque, presents torque curves for each seat material, and provides correction factors for media and the type of service such as on-off operation, cycle frequency, etc.

Flow Coefficient

Valve Size	C _v	Equivalent Length of Schedule 40 Pipe (feet)
¼", ⅜"	8	0.9
½"	8	3.1
¾"	12	6.3
1"	32	3.1
1¼"	46	6.3
1½"	82	4.3
2"	120	7.5

Series 45 Ball Valve

Compact, Large Diameter, Three-piece Ball Valves

Substantially Reduced Installation and Maintenance Costs

For OEM equipment and packaged piping systems, Worcester Controls Series 45 ball valves provide the best performance for the least installed cost in the 2½"–6" size range. Flanges are an integral part of the valve design, providing savings in flanges, nuts, bolts and labor. Three-piece construction also means that the valve functions as both valve and union. This is a valuable feature in welded piping systems where line breaks are required.

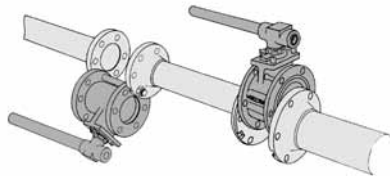

The Series 45 valves offer all the advantages of Worcester's Series 44 three-piece and Series 51/52 flanged valves: downstream seat sealing, low operational torque, and bottom entry, blowout-proof stem. Multiple stem seal rings in a deep packing box assure zero leakage and Worcester Controls' unique seat design assures positive shutoff.

Quarter-turn for ease of operation. Wrench indicates direction of flow. Wrench extension may be fitted in mid-position or extended to either side.

Unique stem seal compensates for wear and temperature fluctuations.

Resilient seats give bubbletight sealing. Unique design gives low torque and reduced seat wear.

Available with variety of pipe ends: screwed, socket weld or butt weld.

Compact, safe, bottom entry adjustable stem. Cannot be removed when valve is under pressure.

Three-piece body design. Serves as both a valve and a union.

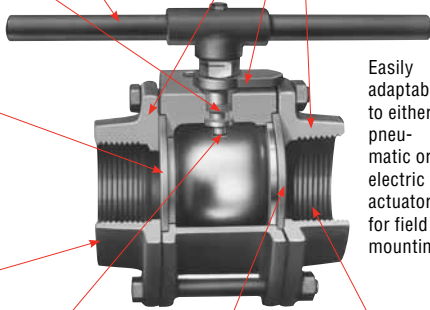

Separate body seals prevent atmospheric leakage.

Smooth two-way flow path for maximum CV.

Easily Automated for On/Off or Modulating Control

The lightweight, compact design of the Series 45 valves combined with Worcester Controls' own Series 39 pneumatic actuators creates a control package that's small yet efficient. Worcester Controls' actuators are engineered to match the performance of the valve for optimum power and safety. For detailed sizing instructions see Worcester Controls' Actuator Sizing Manual, bulletin WCASS0001. A wide range of options is available to complement your pneumatic or electric package, from computer compatible controls to limit switches to Cycle Length Control. For on/off or throttling applications, when used with a positioner, the actuated 45 Series valve is a dependable, precise unit. Because Flowserve Worcester Controls supplies all the elements of your control packages, we are your single source if you ever need replacement parts or service.

Flow Coefficient

Valve Size	C _v	Equivalent Length of Schedule 40 pipe (feet)
2½"	240	5
3"	350	8.3
4"	720	10.4
6"	1020	20.4

Body seals have pressure/temperature ratings that equal or exceed the rating of the seat.

Seat Pressure/Temperature Ratings

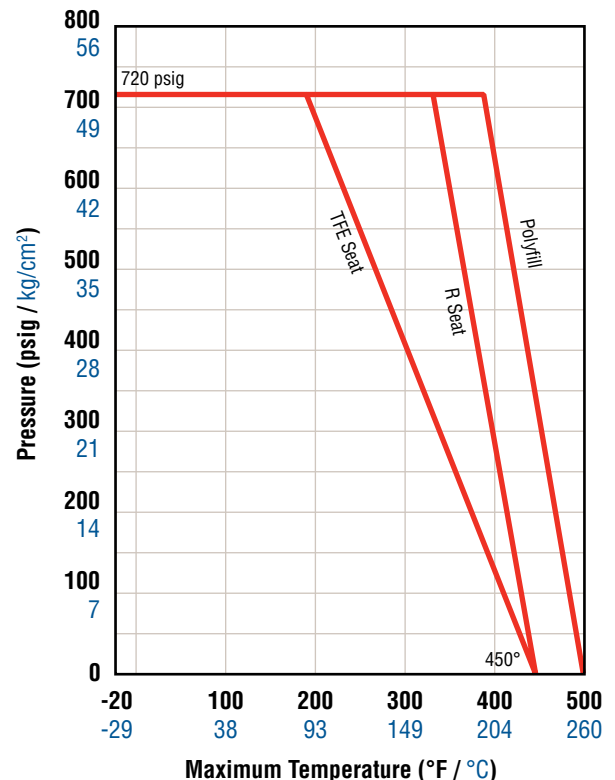

Series 59 Full-Port Ball Valves

Manual and automated valves for processes requiring maximum flow area

Full-port ball valves are recommended for processes requiring minimum restriction through piping, shutoff valves, and other equipment. For example, pump inlet valves are often full-port valves. Full-port valves are also useful in systems handling slurries, viscous fluids and fluids with residues, and where the capacity to pig lines is desired.

¼"–2" Series 59 valves are rated to ANSI Class 600. 3" and 4" valves are rated to ANSI Class 300.

Flowserve Worcester Controls offers a complete line of pneumatic and electric automation packages for on/off or throttling control, including the Series 39 twin piston pneumatic actuator and the Series 75 electric actuator.

Series 59 full-port valves are available in a fire-rated configuration AF59 in sizes ½", ¾", 1", 1½", and 2". Flanged ANSI Class 150 and 300 full-port valves are available in sizes ½"–10".

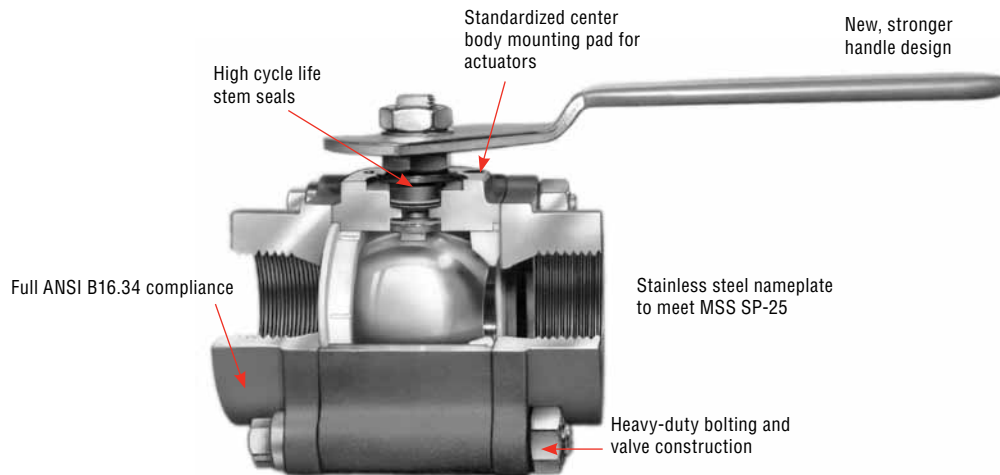

Seat Pressure/Temperature Ratings

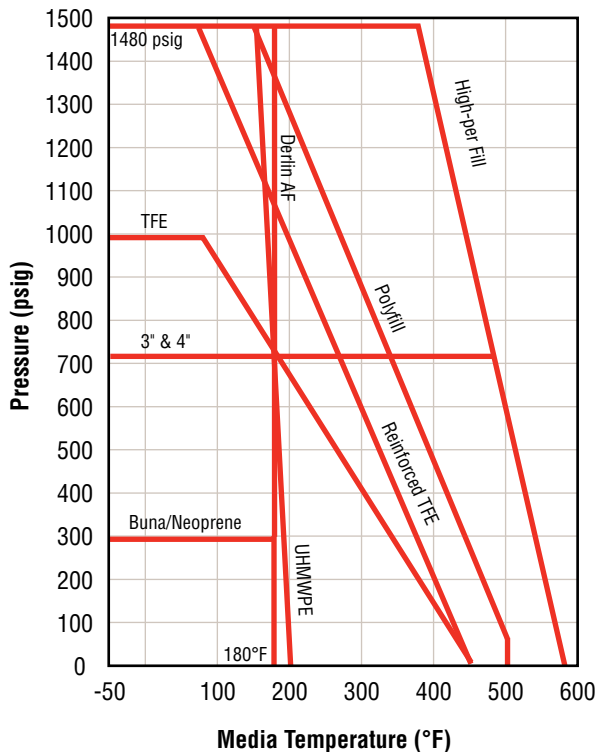

Flow coefficient

Valve Size	C _v	Equivalent Length of Schedule 40 pipe (feet)
¼", ⅜"	8	0.9
½"	38	1.4
¾"	71	1.0
1"	110	1.9
1¼"	230	2.1
1½"	350	2.1
2"	600	2.1
3"	1330	3.0
4"	2420	2.7

NOTE: Body seals have a pressure/temperature rating that equals or exceeds the seat. Oxygen service valves use Polyfill in place of PEEK.

Dimensions

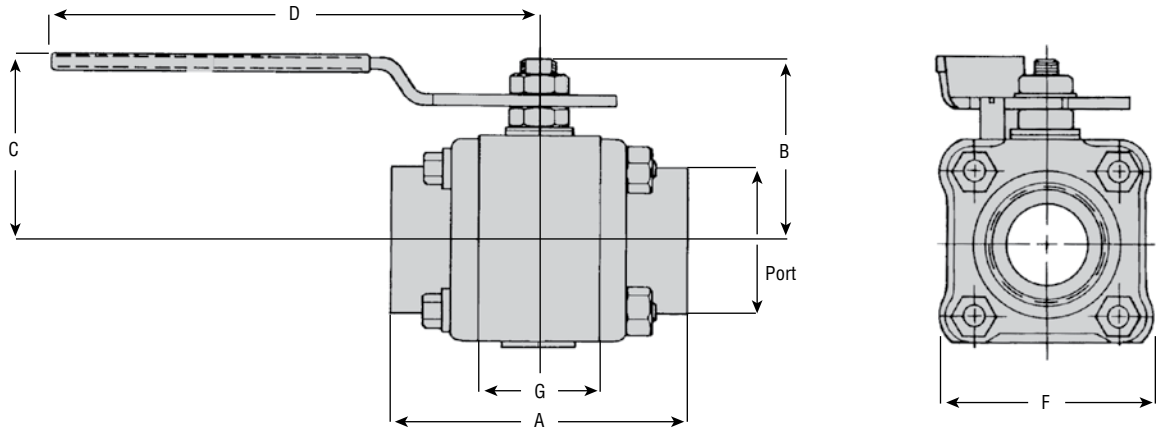

Series 44

inches / millimeters

Valve Size	A	B	C	D	F	G	Socket Weld SW		O.D. Tube End SWO		O.D. Tube End TE	
							H	J	K	L	M	N
1/4"	2.54	1.55	1.76	5.53	1.75	.813	.555	.44	—	—	.378	.37
	64.5	39.4	44.7	140	44.5	20.7	14.1	11.2	—	—	9.6	9.4
3/8"	2.54	1.55	1.76	5.53	1.75	.813	.690	.44	—	—	.503	.44
	64.5	39.4	44.7	140	44.5	20.7	17.5	11.2	—	—	12.8	11.2
1/2"	2.54	1.55	1.76	5.53	1.75	.813	.855	.44	.510	.44	.628	.56
	64.5	39.4	44.7	140	44.5	20.7	21.7	11.2	13.0	11.2	15.6	14.2
3/4"	2.76	1.64	1.86	5.53	2.00	.969	1.065	.56	.760	.56	.878	.81
	70.1	41.7	47.2	140	50.8	24.6	27.1	14.2	19.3	14.2	22.3	20.6
1"	3.66	2.19	2.28	6.53	2.38	1.25	1.330	.72	1.01	.56	1.129	.97
	93.0	55.6	57.9	166	60.5	31.8	33.8	18.3	25.7	14.2	28.7	24.5
1 1/4"	4.16	2.38	2.47	6.53	2.70	1.63	1.675	.72	1.26	.62	1.379	1.03
	105	60.5	62.7	166	68.6	41.3	42.5	18.3	32.0	15.8	35.0	26.2
1 1/2"	4.50	2.88	2.83	8.03	3.16	1.91	1.915	.72	1.51	.62	1.629	1.15
	114	73.2	71.9	204	80.3	48.4	48.6	18.3	38.4	15.8	41.4	29.2
2"	4.94	3.06	3.02	8.03	3.56	2.22	2.406	.84	2.01	.67	2.129	1.15
	126	77.7	76.7	204	90.4	56.3	61.1	21.3	51.1	17.0	54.1	29.2

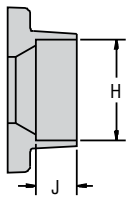

Socket weld
SW

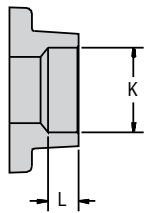

O.D. Tube End*
SWO

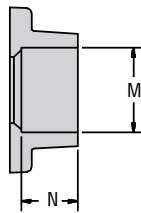

Tube End TE
K, L or M
(Copper Tube)

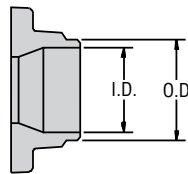

Butt Weld BW
Sch. 5, 10 (Stainless Steel)
Sch. 40, 80 (Carbon Steel)

* The inside configuration of O.D. tube pipe ends varies by size and material.

NOTE: For XBO and TC ends, call Flowserve.

Series 44 (continued)

inches / millimeters

Valve Size	Butt Weld Stainless Steel				Butt Weld Carbon Steel				Port	Approx. Weight lb. / kg
	BW5 Sch. 5		BW1 Sch. 10		BW4 Sch. 40		BW8 Sch. 80			
	O.D.	I.D.	O.D.	I.D.	O.D.	I.D.	O.D.	I.D.		
1/4"	—	—	.55	.406	.550	.344	—	—	.44	1.10
	—	—	14.0	10.3	14.0	8.7	—	—	11.2	.50
3/8"	—	—	.67	.547	.670	.516	—	—	.44	1.10
	—	—	17.0	13.9	17.0	13.1	—	—	11.2	.50
1/2"	.840	.710	.84	.672	.840	.625	.840	.550	.44	1.10
	21.3	18.0	21.3	17.1	21.3	15.9	21.3	14.0	11.2	.50
3/4"	1.05	.920	1.05	.875	1.05	.812	1.05	.753	.56	1.75
	26.7	23.4	26.7	22.2	26.7	20.6	26.7	26.7	14.2	.79
1"	1.31	1.18	1.31	1.09	1.31	1.05	1.31	.957	.81	3.10
	33.3	30.1	33.3	27.8	33.3	26.6	33.3	24.3	20.6	1.41
1 1/4"	1.66	1.53	1.66	1.44	1.66	1.38	1.66	1.27	1.00	4.50
	42.2	38.9	42.2	36.5	42.2	35.1	42.2	32.3	25.4	2.04
1 1/2"	1.91	1.77	1.91	1.67	1.91	1.59	1.91	1.52	1.25	6.20
	48.5	45.0	48.5	42.5	48.5	40.5	48.5	38.6	31.8	2.82
2"	2.38	2.24	2.38	2.15	2.38	2.06	2.38	1.93	1.50	9.50
	60.5	57.0	60.5	54.5	60.5	52.4	60.5	48.9	38.1	4.31

Dimensions are for reference only. For tolerances, consult Flowserve.

Dimensions

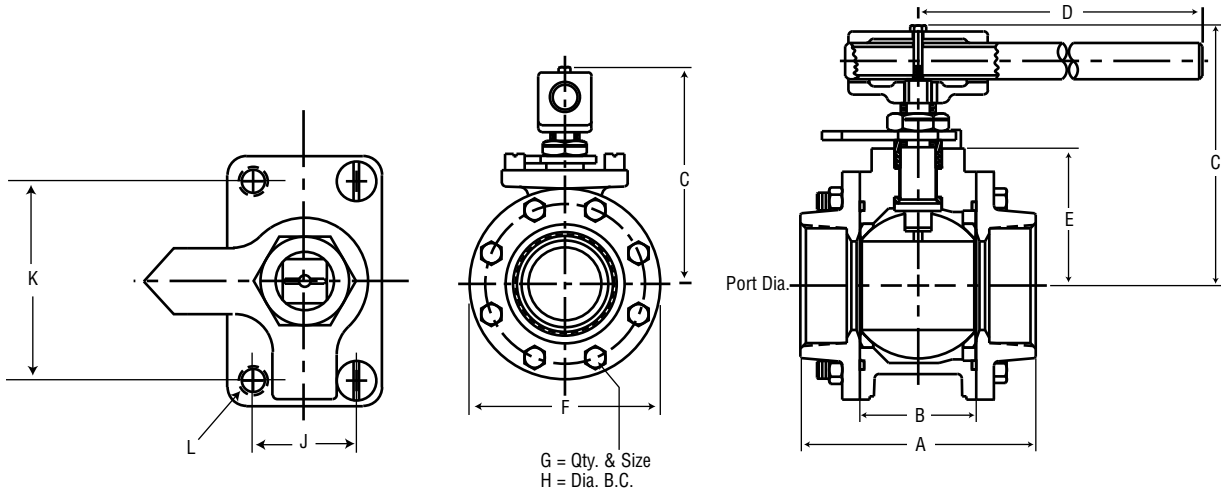

Series 45

inches / millimeters

Valve Size	Port	A	B	C	D	E	F	G	H	J	K	L
2½"	2.00	5.86	2.86	5.58	8.82	2.92	5.84	6 x 7/16-20	4.92	1.25	2.75	M8
	50.8	148.8	72.6	141.7	224.0	74.2	148.3		124.9	31.8	69.9	
3"	2.50	6.66	3.28	7.22	22.00	3.88	6.44	6 x ½-20	5.50	1.75	3.38	M10
	63.5	169.2	83.3	183.4	558.8	98.6	163.6		139.7	44.5	85.9	
4"	3.25	8.41	4.28	7.84	22.00	4.48	8.12	8 x 9/16-18	6.87	1.75	3.38	M10
	82.6	213.6	108.8	199.1	558.8	113.8	206.2		174.5	44.5	85.9	
6"	4.38	11.75	5.75	11.21	26.00	6.19	11.12	8 x ¾-10	9.37	3.00	4.00	M12
	111.3	298.5	146.0	284.7	660.4	157.2	282.4		238.0	76.2	101.6	

Valve Size	M	N	P	Socket Weld		Butt Weld				Weight lbs. kg
						BW1		BW4		
				R	S	O.D.	I.D.	O.D.	I.D.	
2½"	.73	.55	.79	1.17	2.90	2.87	2.64	2.87	2.47	21.0
	18.5	13.9	20.0	29.7	74.2	72.9	67.1	72.9	63.2	9.53
3"	.65	.75	.88	1.31	3.53	3.50	3.25	3.50	3.07	30.0
	16.5	19.1	22.4	33.3	89.6	89.9	82.5	88.9	77.9	13.56
4"	.65	.75	.88	1.56	4.53	4.50	4.26	4.50	4.03	50.2
	16.5	19.1	22.4	39.6	115.0	114.3	108.2	114.3	102.0	22.7
6"	1.03	1.12	1.39	2.00	6.65	6.63	6.36	6.63	6.07	80.1
	26.2	28.4	35.3	50.8	168.9	168.3	161.5	168.3	154.3	36.33

Dimensions are for layout purposes only. For tolerances, contact Flowserve. Metric dimensions are converted from standard English.

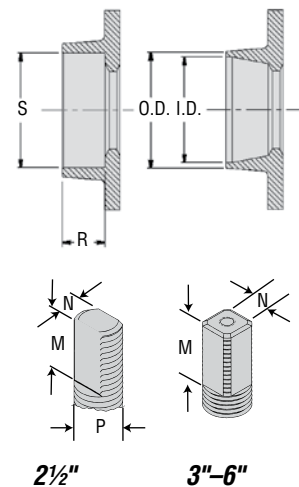

Dimensions

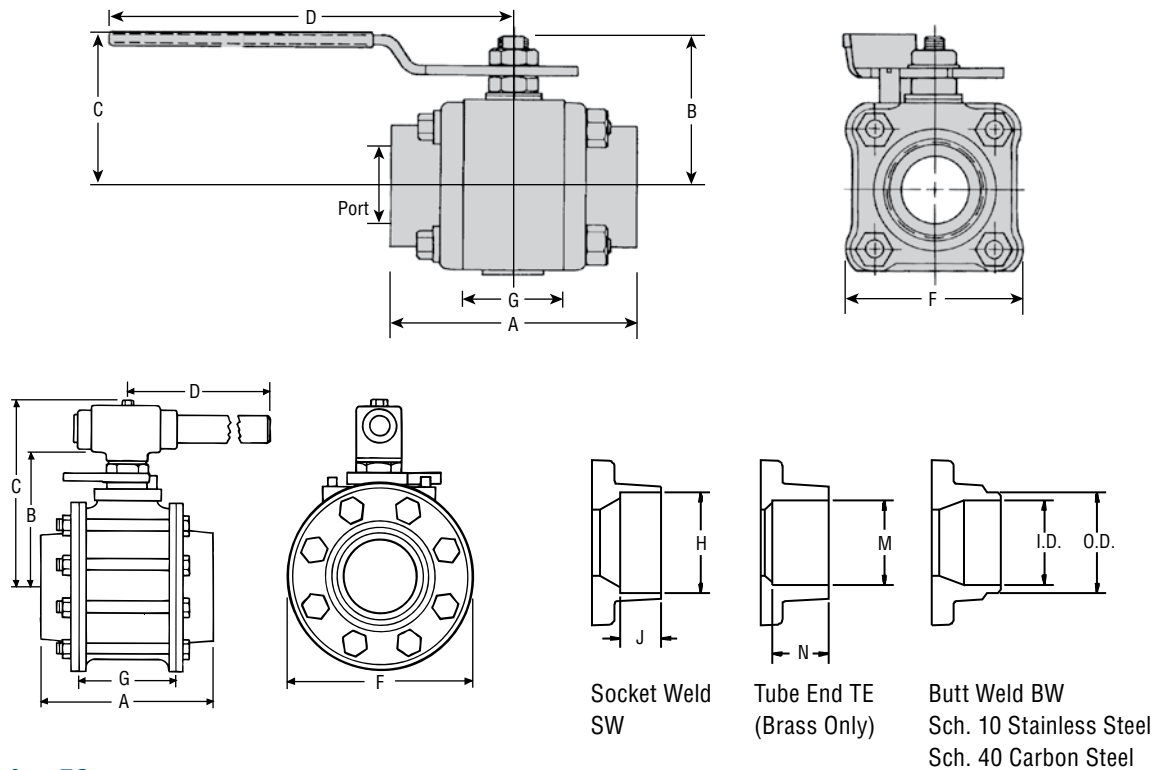

Series 59

inches / millimeters

Valve Size	A	B	C	D	F	G	Socket Weld		Tube End		Butt Weld Schedule 10		Butt Weld Schedule 40		Port	Weight lb. / kg
							H	J	M	N	O.D.	I.D.	O.D.	I.D.		
1/4"	2.54	1.55	1.76	5.53	1.75	.813	.555	.440	.378	.370	.550	.406	.550	.344	.440	1.10
	64.52	39.4	44.7	140.5	44.5	20.7	14.1	11.2	9.6	9.40	14.4	10.3	14.4	8.7	11.2	0.5
3/8"	2.54	1.55	1.76	5.53	1.75	.813	.690	.440	.504	.449	.670	.547	.670	.516	.440	1.10
	64.52	39.4	44.7	140.5	44.5	20.7	17.5	11.2	12.8	11.2	17.0	13.9	17.0	13.1	11.2	0.5
1/2"	2.76	1.64	1.86	5.53	2.00	.969	.855	.440	.628	.560	.840	.672	.840	.625	.560	1.80
	70.1	41.7	47.24	140.5	50.8	24.6	21.7	11.2	15.6	14.2	21.3	17.1	21.3	15.9	14.2	0.82
3/4"	3.66	2.19	2.28	6.53	2.38	1.25	1.07	.560	.878	.810	1.05	.875	1.05	.812	0.81	3.10
	92.96	55.6	57.91	165.9	60.5	31.8	27.1	14.2	22.3	20.6	26.7	22.2	26.7	20.6	20.6	1.41
1"	4.16	2.38	2.47	6.53	2.70	1.63	1.33	.720	1.13	.97	1.31	1.09	1.31	1.05	1.00	4.50
	105.7	60.5	62.74	165.9	68.6	41.3	33.8	18.3	28.7	24.6	33.3	27.8	33.3	26.6	25.4	2.05
1 1/4"	4.50	2.88	2.83	8.03	3.16	1.91	1.68	.720	1.38	1.03	1.66	1.44	1.66	1.38	1.25	6.20
	114.3	73.2	71.88	204.0	80.3	48.4	42.5	18.3	35.0	25.2	42.2	36.5	42.2	35.1	31.8	2.81
1 1/2"	4.94	3.06	3.02	8.03	3.56	2.22	1.92	.720	1.63	1.15	1.91	1.67	1.91	1.59	1.50	9.50
	125.5	77.7	76.71	224.0	90.4	56.3	48.6	18.3	41.4	29.2	48.5	42.5	48.5	40.5	38.1	4.31
2"	5.86	4.56	5.58	8.82	4.57	2.86	2.41	.840	—	—	2.38	2.15	2.38	2.06	2.00	25.00
	149.0	116	142.0	224.0	116.0	72.6	61.2	21.34	—	—	60.5	54.5	60.5	52.3	50.8	11.3
3"	7.54	6.31	7.84	22.00	8.13	4.28	3.54	1.31	—	—	3.50	3.25	3.50	3.07	3.25	50.20
	191.0	160.3	199.0	558.8	206.0	108.0	89.9	33.27	—	—	88.9	82.55	88.9	77.98	82.55	22.8
4"	11.75	8.96	11.21	26.00	11.13	5.75	4.53	1.56	—	—	4.50	4.26	4.50	4.03	4.03	80.10
	298.0	227.9	284.0	660.0	282.0	146.0	115.1	39.62	—	—	114.3	108.2	114.3	102.4	102.4	36.4

Dimensions are given for layout purposes only. For tolerances, consult your Worcester Controls distributor. Metric equivalents are converted from Standard English.

Specifications

Series 44 Ball Valves

Valve Sizes: 1/4", 3/8", 1/2", 3/4", 1", 1 1/4", 1 1/2", 2"

Valve Body Pressure Rating For Carbon Steel, Stainless Steel, Alloy 20 Valves: ANSI Class 600

1/4"-2"	Carbon Steel	1480 psi
1/4"-2"	Stainless Steel	1440 psi
1/4"-2"	Alloy 20®	1200 psi

Valve Body Pressure Rating for Brass Valves:

1/4"-1"	1500 psi
1 1/4"-2"	1000 psi

This is the body pressure rating. Seat selection may lower the valve pressure rating. Example: A 3/4" Series 44 brass valve has a rating of 1500 psi at 70°F. Selection of TFE seats, operating at a fluid temperature of 160°F, limits total allowable pressure in the valve to 800 psi.

Body and Pipe End Materials:

Brass, Carbon Steel, 316 Stainless Steel, Alloy 20

Ball: Brass, 316 Stainless Steel, Monel®, Alloy 20, Hastelloy C®

Design Specifications:

ANSI B16.34 (if ordered with Hydro Test and CMTRs)
ANSI B16.25 – Butt weld ends (weld end preparation)
ANSI B16.11
ANSI B1.20.1 – NPT pipe threads
MSS SP-25 – Valve marking
MSS SP-72 – Socket weld ball valves
NACE – MRO I-75 1984 Rev. Category 3

Seats: Buna, Neoprene, TFE, glass-reinforced TFE, UHMWPE (ultra high molecular weight polyethylene), Polyfill (carbon, graphite filled TFE), High-per Fill, Lubetal

Body Seals, Choice of: Buna, Neoprene, Viton®, EPDM, TFE, UHMWPE, TFE-coated 316 Stainless Steel, graphite-coated 316 Stainless Steel

Seals and Thrust Bearings: PEEK, Graphite and Polyfill

Temperature Range: Dependent upon seal and seat choice, will operate from -50°F to 600°F.

Pressure Range: Valves will operate from 1 micron absolute to 1480 psi.

Seat/Seal Leakage: Standard valves, less than 1 x 10⁻⁶ cc He/sec in board and through (bubble-tight is 1 x 10⁻⁴ cc He/sec). With preparation, leakage will be less than 2 x 10⁻⁹ cc He/sec. All valves 100% tested to bubble-tight standards.

Optional External Valve Trim: 300 Series stainless steel external components are available as an option on brass and carbon steel valves. They are standard on stainless steel and Alloy 20 valves.

S-7: Complete stainless steel trim: handle, handle nut, lock washer, retaining nut, Belleville washers, body bolts, nuts, stop pin.

Series 45 Ball Valves

Sizes: 2 1/2", 3", 4", 6"

Style: Three-piece

Rating: ANSI Class 300

Ends: Screwed, Socket Weld, Butt Weld Schedule 40 (CS), Butt Weld Schedule 10 (SS)

Body: Carbon Steel, Type 316 Stainless Steel

Ball & Stem: Type 316 Stainless Steel

Seats: Reinforced fluoropolymer, Polyfill®, fluoropolymer, UHMWPE

Body Seals: TFE (TFE coated Stainless Steel "S" gasket with Polyfill seats) or UHMWPE with UHMWPE seats optional on 2 1/2" valve.

Max. Pressure: 720 psi

Max. Temp: 450°F – TFE and Reinforced TFE seats
500°F – Polyfill seats

Leakage Rate: Bubble-tight

Service*: Manual on/off, Automated on/off (electric or pneumatic actuation), Throttling Control (electric or pneumatic actuation)

Flow: Bidirectional

Standards: SE valves meet ANSI B2.1
SW valves meet ANSI B16.11
BW valves meet ANSI B16.25
All styles: Meet Coast Guard requirements
Meet NACE MR01-75

* For steam service ratings, refer to Worcester Steam Service Data Sheet (SSD) for ratings. This data sheet is found in the Engineering Section of the general catalog binder.

Series 59 Ball Valves

Sizes: ¼", ⅜", ½", ¾", 1", 1¼", 1½", 2", 3", 4"

Style: Three-piece, four-bolt (¼"–2")
Three-piece, eight-bolt (3"–4")

Valve Pressure Rating*: ¼"–2" Carbon Steel and Stainless Steel Valves, ANSI Class 600
3"–4" Carbon Steel and Stainless Steel Valves, ANSI Class 300
¼"–1" Brass Valves, 1500 psi
1¼"–1½" Brass Valves, 1000 psi

Body: Carbon Steel, 316 Stainless Steel, Brass
(valve sizes ¼"–1½")

Pipe Ends: Screw End, Socket Weld, Butt Weld, Tube End

Ball: Chrome Plated Brass
316 Stainless Steel

Temp. Range: Depends on seat and seal choice;
will operate from -20°F to 600°F

Seat/Seal Leakage: Standard valves, less than 1×10^{-6} cc He/sec inboard and through (bubbletight is 1×10^{-4} cc He/sec). With preparation, leakage will be less than 2×10^{-9} cc He/sec. All valves 100% tested to bubbletight standards.

Flow: Bidirectional

Design Specifications:

ANSI B16.34 (¼"- 2", if ordered with Hydro Test and CMTRs)
ANSI B16.25 – Butt Weld Ends (Weld End Preparation)
ANSI B16.11
ANSI B1.20.1 – NPT Pipe Threads
MSS SP25 – Valve Marking
MSS SP72 – Socket Weld Ball Valves
NACE – MRO 1-75 Category 3

UL Listed: Flammable liquid shutoff (YRBX)
(¼"–2") Anhydrous ammonia shutoff (YQAR)
Compressed gas shutoff, including oxygen (YQNZ)
Trim and drain valves (VQGU)

Weld-in-Place Valves (V67): ¼"–1½" Series 59 valves with "G" body seals and seats of reinforced TFE (R), Polyfill® (P), or High-per Fill® (X) may be welded to the pipeline in the assembled condition. (Must have V67 suffix in ordering code).

Optional S-7: (¼"–1½") Complete stainless steel trim: handle, nut, lock washer, retaining nut, Belleville washers, body bolts, nuts, stop pin.

External Valve Trim: External components are available as an option on brass and carbon steel valves. They are standard on ¼"–1½" stainless steel valves. For 2"–4", they are available through custom products. Certified Material Testing Reports (CMTRs) are available with B16.34.

*These are valve body pressure ratings. Seat selection may derate the valve. Example: a 1" carbon steel Series 59 valve has a rating of 1480 psi at 70°F. Selection of reinforced TFE seats operating at fluid temperature of 200°F limits allowable pressure in the valve to 1000 psi.

Parts Identification

Series 44

No.	Part	Qty	Material
1	Valve Body	1	Brass ASTM B283 Gr. C3770 Forged
			Carbon Steel ASTM A105 Forged or ASTM A216 Gr. WCB Cast
			Stainless Steel ASTM A351 Gr. CF8M Cast
			Alloy 20 ASTM A351 Gr. CN7M Cast
2	Pipe Ends**	2	Same as body material except stainless weld ends and Tri-Clamp® are Grade CF3M
3, 4	Ball and Stem Combinations	1	Brass ASTM B16 Gr. H02 Hard Chrome Plated ball; ASTM B16 Stem
			Stainless Steel ASTM A479 Gr. 316 S.S.
			Alloy 20 ASTM B473
			Monel ASTM B164 Gr. N04400
			Hastelloy C ASTM B574 Gr. N10276
5	Seats	2	Buna, Neoprene, TFE, Reinforced TFE, Polyfill, UHMWPE, High-per Fill, Lubetal
6	Body Seals	2	Buna, Neoprene, TFE, EPR, Viton, TFE Coated, 316 S.S. "S" gasket, UHMWPE, Graphite Coated 316 S.S. "S" Gasket
7	Stem Seal	2	Polyfill (UHMWPE with UHMWPE seats; Graphite with High-per Fill seats)
8	Thrust Bearing	1	Polyfill (UHMWPE with UHMWPE seats; PEEK with High-per Fill seats; Delrin with Lubetal seats)
9	Stem Seal Follower	1	316 Stainless Steel

No.	Part	Qty	Material
10	Belleville Washers†	2	Carbon Steel: Zinc Plated ANSI 301 Stainless Steel
11	Retaining Nut†	2	Carbon Steel: Zinc Plated; ANSI 300 Series Stainless Steel: Zinc Plated
12	Handle Assembly†	1	Carbon Steel: Zinc Plated ANSI 300 Series Stainless Steel Vinyl Covered
13	Stop Pin†	1 or 2	Carbon Steel: Zinc Plated S.S. ASTM A276 300 Series
14, 15	Body Bolts and Nuts†	4	Carbon Steel and Brass Valves Bolt – A193 Gr B7; Zinc Plated Nut – ASTM A194 Gr. 2H; Zinc Plated Stainless Steel and Alloy 20 Valves Bolt – ASTM A193 Gr. B8; Zinc Plated Nut – ASTM A194 Gr. 8 S7 Stainless Steel Externals Option Bolt – ASTM A193 Gr. B8; Zinc Plated Nut – ASTM A194 Gr. 8
16	Lockwasher†	1	Carbon Steel: Zinc Plated Stainless Steel 300 Series
17	Thrust Bearing Protector*	1	PEEK (UHMWPE with UHMWPE seats; Delrin with Lubetal seats)
18	Seal Protector*	1	PEEK
19	Name Plate (not shown)	1	Stainless Steel ANSI 304

†Stainless Steel standard on Series 4466 and 44AA valves.

*Oxygen Service Valves use Polyfill in place of PEEK.

**All stainless steel weld ends in 316L.

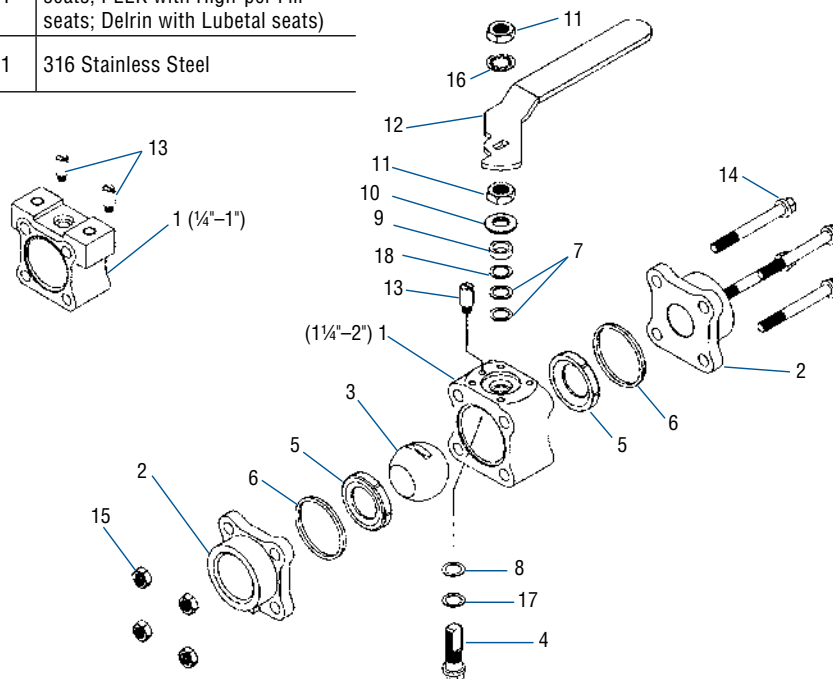

Parts Identification

Series 45

Part	Description	Qty	Material
1	Hex. Head Bolt	1	Carbon Steel
2	Wrench Block	1	Mal. Iron
3	Wrench Extension	1	Carbon Steel
4	Retaining Nut	1	Carbon Steel/Zinc Plated or Stainless Steel
5	Stop	1	Carbon Steel/Black Oxide Coated
6	Follower	1	Stainless Steel
7	Stem Seal	3	TFE Glass Filled
8	Centering Washer (3"-6" only)	1	316 Stainless Steel or Carbon Steel
9	Thrust Bearing	1	TFE Glass Filled
10	Stem	1	316 Stainless Steel
11	Body	1	Carbon Steel*, 316 Stainless Steel
12	Body Seal	2	TFE, TFE coated 316 S.S., UHMWPE
13	Ball	1	316 Stainless Steel

Part	Description	Qty	Material
14	Seat Retainer	1	Carbon Steel, 316 Stainless Steel
15	Seat	2	TFE, TFE Glass Filled, Polyfill, UHMWPE
16	Stop Screw	2	Carbon Steel/Black Oxide Coated
17	Pipe End B.W.	2	316L Stainless Steel, Carbon Steel*
18	Pipe End S.W.	2	316L Stainless Steel, Carbon Steel*
19	Pipe End S.E.	2	316 Stainless Steel, Carbon Steel*
20	Body Bolt 2½" & 3"	6	Carbon Steel/Black Oxide Coated
	Body Bolt 4" & 6"	8	Carbon Steel/Black Oxide Coated
21	Body Nut 2½" & 3"	6	Carbon Steel/Black Oxide Coated
	Body Nut 4"	8	Carbon Steel/Black Oxide Coated
	Body Nut 6"	16	Carbon Steel/Black Oxide Coated

* Black Coated, Oil Dipped

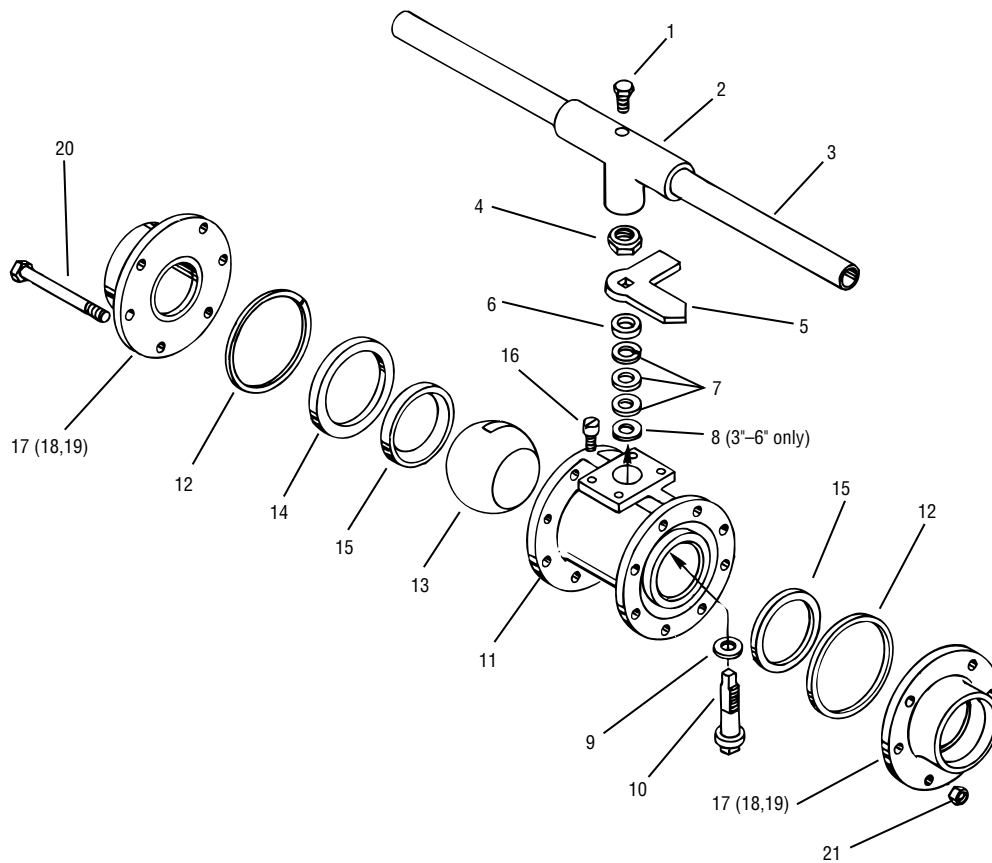

Parts Identification

Series 59

No.	Part	Qty	Material
1	Body	1	C.S., 316 S.S., Brass
2	Pipe End	2	C.S., Brass, 316 S.S., (316L for weld ends)
3	Ball	1	316 S.S., Chrome-Plated Brass
4	Stem	1	316 S.S., Brass
5	Seat	2	TFE, Reinforced TFE, Buna, Neoprene, Polyfill, UHMWPE, High-per Fill, Delrin®AF
6	Body Seal	2	Buna, Viton®, EPR, TFE, Neoprene, TFE Coated 316 S.S. "S" Gasket, Graphite Coated 316 S.S. "S" Gasket, UHMWPE Graphite (2" only)
7	Stem Seal	2	Polyfill (UHMWPE with UHMWPE seats; Graphite with High-per Fill Seats)
8	Thrust Bearing	1	Polyfill (UHMWPE with UHMWPE seats; PEEK with High-per Fill seats; Delrin with Delrin AF seats)
9	Stem Seal Follower	1	316 S.S.
10	Belleville Washers	2	Carbon Steel: Zinc-Plated or S.S.
11	Retaining Nut	2	Carbon Steel: Zinc-Plated or S.S.
12	Handle Assembly	1	Carbon Steel: Zinc-Plated or S.S. Vinyl Sleeve
13	Stop Pin (1" and up)	1	¼"- 1½" S.S. or C.S. Zinc-Plated;
	Stop Pin (¼"- ¾")	2	2"- 4" C.S., Black Oxide-Coated

No.	Part	Qty	Material
14	Body Bolts	4	¼"-2" C.S.: ASTM A193 GR-B7 S.S.: ASTM A193 GR-B8
		8	3"- 4" C.S.: Black Oxide-Coated
15	Body Nuts	4	¼"- 2" C.S.: ASTM A194 GR-2H S.S.: ASTM A194 GR-B8
		8	3"- 4" C.S.: Black Oxide-Coated
16	Lockwasher	1	Carbon Steel: Zinc-Plated or S.S.
17	Thrust Bearing*	1	PEEK (UHMWPE with UHMWPE seats; Delrin with Delrin AF seats)
18	Seal Protector*	1	PEEK
19	Nameplate (not shown)	1	304 Stainless Steel
20	Stem Seal	3	Size 2", 3", 4" Valves Glass-filled TFE
21	Centering Washer	1	C.S.; 316 S.S. (3" & 4" only)
22	Thrust Bearing	1	Glass-filled TFE
23	Seat Retainer	1	Carbon Steel or 316 S.S.
24	Stop	1	C.S.: Black Oxide-Coated
25	Hex Head Bolt	1	Carbon Steel
26	Wrench Block	1	Malleable Iron
27	Wrench Extension	1	Carbon Steel
28	Retaining Nut	1	Carbon Steel: Zinc-Plated or S.S.

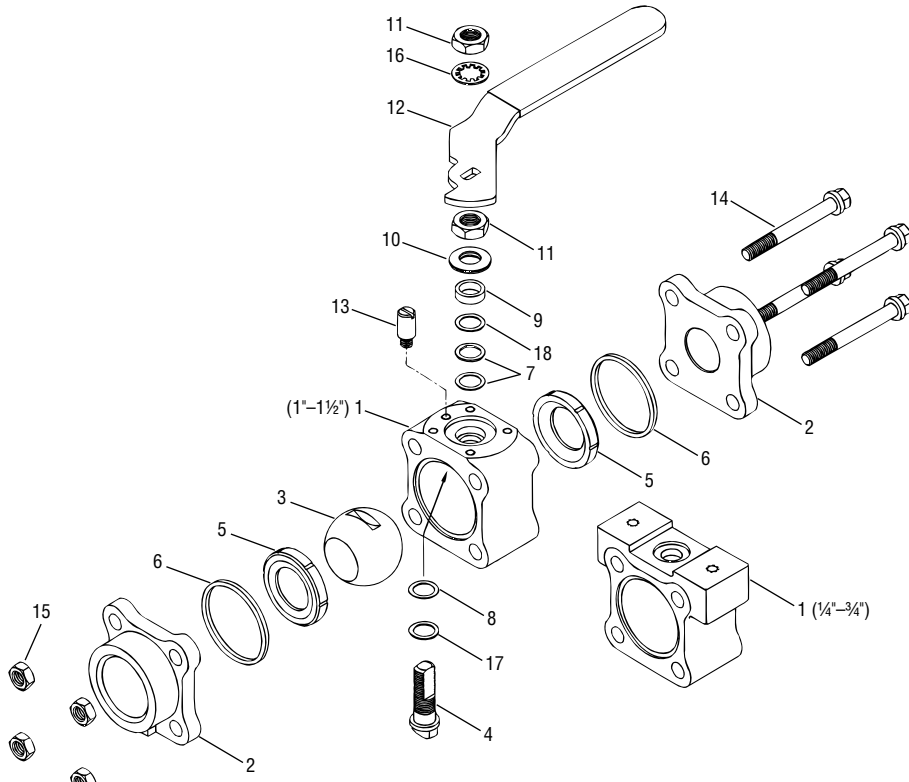

1/4"-1 1/2"

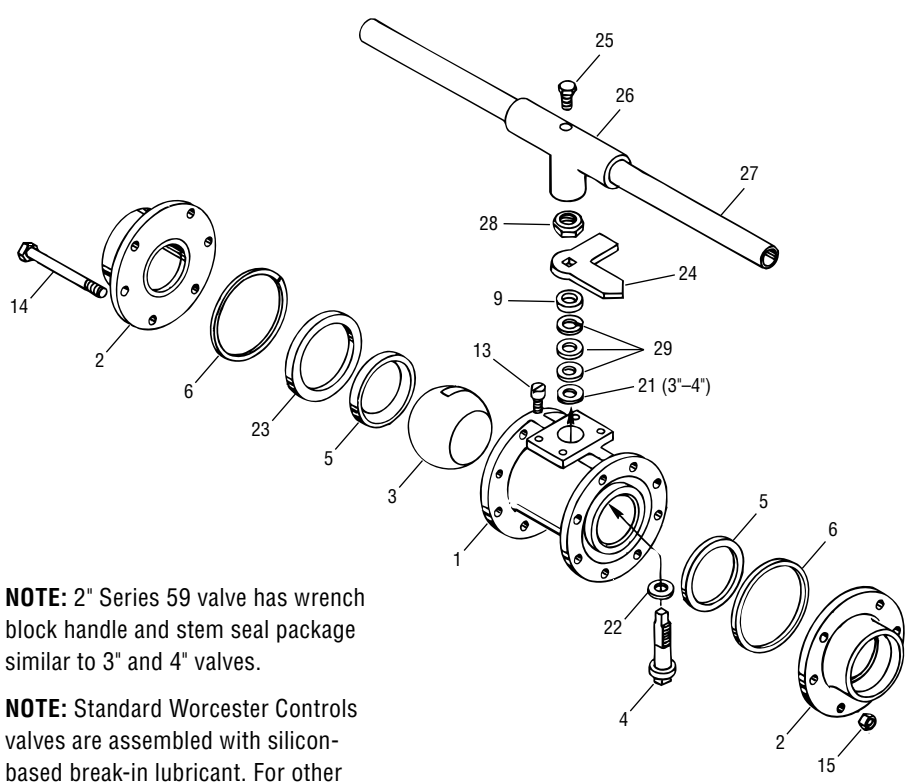

2"



3" and 4"

NOTE: 2" Series 59 valve has wrench block handle and stem seal package similar to 3" and 4" valves.

NOTE: Standard Worcester Controls valves are assembled with silicon-based break-in lubricant. For other options consult your distributor or Flowserve.

How to Order

Series 44

1/4"		44	6	6	T*		SW **
Size	Options	Series	Body & Pipe Ends	Ball & Stem	Seats	Body Seals	End Type
1/4"	Blank – Built with lever handle	44	1 – Brass	1 – Brass (chrome plated)	B – Buna	B – Buna	SE – Screwed Pipe Ends (NPT) Any Sch. Pipe† Carbon Steel, Stainless Steel Alloy 20
3/8"			4 – Carbon Steel		N – Neoprene	N – Neoprene	
1/2"	E – No handle valve built for automation	44	6 – 316 S.S.	4 – Carbon Steel (chrome plated)	T – TFE	T – TFE	Butt Weld (BW) ends: BW1 – Stainless Steel, Sch. 10 BW4 – Carbon Steel, Sch. 40 BW4 – Stainless Steel, Sch. 40 BW5 – Stainless Steel, Sch. 5 BW8 – Carbon Steel, Sch. 80
3/4"			A – Alloy 20		R – Reinforced TFE	E – EPR	
1"	A – No handle††	44	A – Alloy 20	6 – 316 S.S.	P – Polyfill	V – Viton	TE – Solder/Sweat Ends Brass – Type K, L, or M copper tube
1 1/4"					7 – Monel	U – UHMWPE	
1 1/2"	B – No handle††			A – Alloy 20	X – High-per Fill	G – Graphite-Coated 316 S.S.	SW – Socket Weld Ends, Any Sch. Pipe†, Carbon Steel, Stainless Steel, Alloy 20 SWO – Socket Weld Ends O.D. Tube S.S.(not available in 1/4" and 3/8" sizes) TC – Quick Disconnect XBO – Extended Butt Weld NP – No Pipe Ends, body bolts and nuts
2"	G – Stem Grounding Spring			C – Hastelloy C	Y – Lubetal	U – UHMWPE	

**Variations (V-Numbered Options) are noted at the end of the order number if needed. Leave blank if no variations. See list to the right for details.

* Use only one letter if body seal is to be the same material as the seat.

NOTE: TO ORDER V67 WELD-IN-PLACE VALVES: Series 44 valves with "G" body seals and seats of Reinforced TFE (R), Polyfill (P), or High-per Fill (X) may be welded in a line in the assembled condition.

Add V58 to ordering code if full B16.34 compliance is required.

Full ANSI B16.34 compliance requires a hydrotest and certified material test reports.

ORDERING EXAMPLE: 1/4" Series 44 valve with 316 S.S. body, ball and stem, TFE seats and seals, and socket weld ends.

EXTERNALS: Externals, including handles, are normally constructed of zinc plated carbon steel. Handles are vinyl coated. When required, the body bolts, nuts, retaining nut, handle nut, lock washer, stop pin and handle are also available in stainless steel by special order (S-7 suffix in ordering code), and come standard when ordering 4466 Stainless Steel or 44AA Alloy 20 valves.

†All IPS schedules of stainless, carbon and alloy steel pipe, S.P.S. copper pipe and red brass pipe.

††To order a Series 44 valve for use with: 34 or 36 actuators, use prefix ordering code "A". EXAMPLE: 1" A 4446 6 PMSE, or with 39 or 75 actuators, use prefix ordering code "B".

⚠ CAUTION: Ball valves can retain pressurized media in the body cavity when closed. Use care when disassembling. Always open valve to relieve pressure prior to disassembly.

Variations (V-numbers): Listing of V-Number Descriptions

V3	Upstream Relief Hole
V5	Hydrostatic Testing
V6	Source Inspection
V17	Grounding Thrust bearing
V20	Oxygen Service
V32	Oval Handle
V33	Oxygen Service without Source Inspect.
V36	Certificate of Compliance
V37	Certificate of Compliance and Hydro Testing
V38	Assemble without Lubricant
V46	Silicon-free Lubricant
V48	Extended Lever Handle
V58	B16.34 Compliance
V59	Extended Oval Handle
V60	OSHA Lockout
V67	Weld-in-Place Valves
V72	Cert. of Comp. European Pressure
V73	Valves or repair kits with cavity filler seat
V74	CMTRs and Hydro Testing and report
V77	CMTRs

How to Order

Series 45

4"	45	6	6	R	T	SE**
Size	Series	Body & Pipe Ends	Ball & Stem	Seats	Body Seals	End Types
2½"	45	4 – Carbon Steel	6 – 316 Stainless Steel	T – TFE	T – TFE	SE – Screw End
3"		6 – 316 Stainless Steel		R – Reinforced TFE	M – TFE coated 316 S.S.	SW – Socket Weld
4"				P – Polyfill	(2½" only)	BW4 – Butt Weld, Schedule 40, Carbon Steel Only
6"				U – UHMWPE (2½" only)	U – UHMWPE (2½" only)	BW1 – Butt Weld, Schedule 10, Stainless Steel Only NP – No Pipe Ends

**Variations (V-Numbered Options) are noted at the end of the order number if needed. Leave blank if no variations. See list below for details.
Ordering example above depicts: A 4" Series 45 Valve with a 316 Stainless Steel Body, Pipe Ends, Ball and Stem, Reinforced TFE and TFE Seals, with Screw Ends.

Variations (V-numbers): Listing of V-Number Descriptions

- Blank - No Variations
- V3 - Upstream Relief Hole
- V5 - Hydrostatic Testing
- V6 - Source Inspection
- V14 - Handleless Valve
- V17 - Grounding Thrust Bearing
- V20 - Oxygen Service Source Inspection
- V33 - Source Inspection
- V36 - Certificate of Compliance
- V37 - Certificate of Compliance & Hydro Testing
- V46 - Silicone Free Lubricant
- V51 - High Cycle Stem Build
- V73 - Valves or repair kits with cavity filler seat
- V74 - CMTRs and Hydro Testing and report
- V77 - CMTRs

Series 59

1½"	59	6	6	R	T	SW**	
Size	Options	Series	Body & Pipe Ends	Ball & Stem	Seats	Body Seals	End Types
¼"	Blank – Built with lever handle	59	1 – Brass (¼"-1½" only)	1 – Brass	T – TFE	T – TFE	SE – Screw End
¾"	E – No handle valve built for automation			6 – 316 S.S.	R – Reinforced TFE	B – Buna (Brass only)	SW – Socket Weld
½"	A – No handle††		4 – Carbon Steel		U – UHMWPE (¼"-1½" only)	V – Viton	TE – Tube End (Brass Only)
¾"	B – No handle††		6 – 316 S.S.		P – Polyfill	E – EPR	BW1 – Butt Weld, Schedule 10, Stainless Steel
1"	G – Stem Grounding Spring				X – High-per Fill	M – TFE coated 316 S.S. "S" gasket	BW4 – Butt Weld, Schedule 40, Carbon Steel, Stainless Steel
1¼"	K – Locking Handle				B – Buna	G – Graphite Coated 316 S.S. "S" gasket	NP – No Pipe Ends
1½"	V – Vacuum Service Prep X – Oxygen Service Prep				N – Neoprene Y – Delrin AF	U – UHMWPE N – Neoprene	
2"	E – No handle valve built for automation	59	4 – Carbon Steel	6 – 316 S.S.	T – TFE	T – TFE	SE – Screw End
3"	V – Vacuum Service Prep		6 – 316 S.S.		R – Reinforced TFE	Z – Graphite (2" only)	SW – Socket Weld
4"	X – Oxygen Service Prep				P – Polyfill		BW1 – Butt Weld, S.S. BW4 – Butt Weld, C.S., S.S. (2" only) NP – No Pipe Ends

**Variations (V-Numbered Options) are noted at the end of the order number if needed. Leave blank if no variations. See list below for details.
Ordering example depicts 1½" Series 59 with 316 stainless steel body, pipe ends, ball and stem, reinforced TFE seats, TFE body seals, and socket weld ends.

†† To order a Series 59 Valve for use with: 34 or 36 actuators, use prefix ordering code "A". Example: 1" A 5946 PMSE. With 39 or 75 actuators, use prefix ordering code "B".

Variations (V-numbers): Listing of V-Number Descriptions

- V3 - Upstream Relief Hole
- V5 - Hydrostatic Testing
- V6 - Source Inspection
- V14 - Handleless Valve (2"-4")
- V17 - Grounding Thrust Bearing
- V20 - Oxygen Service
- V32 - Oval Handle (¼"-1½")
- V33 - Oxygen Service without Source Inspect.
- V36 - Certificate of Compliance
- V37 - Certificate of Compliance & Hydro Testing
- V38 - Assemble without Lubricant
- V46 - Silicon Free Lubricant
- V48 - Extended Lever Handle (¼"-1½")
- V51 - High Cycle Stem Build (2"-4")
- V58 - B16.34 Compliance
- V59 - Extended Oval Handle (¼"-1½")
- V60 - OSHA Lockout (¼"-1½")
- V67 - Weld-in-Place Valve (¼"-1½")
- V72 - Cert. of Comp., European Pressure Equipment Directive Conformance
- V73 - Valves or repair kits with cavity filler seat
- V74 - CMTRs and Hydro Testing and report
- V77 - CMTRs



United States
Flowserve Corp.
Flowserve Flow Control
1978 Foreman Drive
Cookeville, TN 38501 USA
Telephone: 1 931 432 4021
Telefax: 1 931 432 5518

FCD WCABR1050-01 Printed in USA.

To find your local Flowserve representative:

For more information about Flowserve Corporation, visit
www.flowserve.com or call USA 1 800 225 6989

Monel® is a registered trademark of Inco Alloys International. Hastelloy® is a registered trademark of Haynes International. Tri-Clamp® is a registered trademark of Ladish Co. Viton® is a registered trademark of E.I. duPont. Polyfill® is a registered trademark of Flowserve Corp. Lubetal™ is a trademark of Garlock, Inc. ACCESS™ is a trademark of Flowserve Corp. Alloy 20® is a trademark of CRS Holdings, Inc. Pulsair® is a registered trademark of Flowserve Corp. High-per Fill® is a registered trademark of Flowserve Corp. Dyn-O-Miser® is a registered trademark of Flowserve Corp. Viton®, Teflon®, and Delrin® are registered trademarks of The DuPont Company.

Flowserve Corporation has established industry leadership in the design and manufacture of its products. When properly selected, this Flowserve product is designed to perform its intended function safely during its useful life. However, the purchaser or user of Flowserve products should be aware that Flowserve products might be used in numerous applications under a wide variety of industrial service conditions. Although Flowserve can (and often does) provide general guidelines, it cannot provide specific data and warnings for all possible applications. The purchaser/user must therefore assume the ultimate responsibility for the proper sizing and selection, installation, operation, and maintenance of Flowserve products. The purchaser/user should read and understand the Installation Operation Maintenance (IOM) instructions included with the product, and train its employees and contractors in the safe use of Flowserve products in connection with the specific application.

While the information and specifications contained in this literature are believed to be accurate, they are supplied for informative purposes only and should not be considered certified or as a guarantee of satisfactory results by reliance thereon. Nothing contained herein is to be construed as a warranty or guarantee, express or implied, regarding any matter with respect to this product. Because Flowserve is continually improving and upgrading its product design, the specifications, dimensions and information contained herein are subject to change without notice. Should any question arise concerning these provisions, the purchaser/user should contact Flowserve Corporation at any one of its worldwide operations or offices.

© 2005 Flowserve Corporation, Irving, Texas, USA. Flowserve is a registered trademark of Flowserve Corporation.