

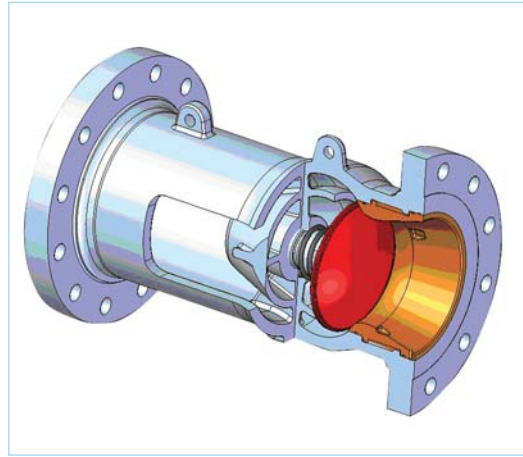

Since its inception in 1962, Stream-Flo Industries Ltd. has been a leader and innovator in the oilfield sector. Stream-Flo's first check valves were perfected and marketed in response to a need for high quality products made to perform and endure in the western Canadian environment.

Stream-Flo continues to be a world industry leader through continuous product development, backed by professional engineers, designers and technicians. Together, they develop, design and produce leading-edge solutions and quality products to make Stream-Flo Industries Ltd. an internationally recognized leader in the check valve industry.



Crown-Europa Nozzle Check Valve

Check valves are primarily used to protect pumps and compressors from damage caused by backflow.

The Crown-Europa Nozzle Check Valve is designed for severe service applications where fast reverse flow exists and conventional check valves are unsuitable for the existing flow conditions.

Installation of the Crown-Europa Nozzle Check Valve offers the systems engineer the opportunity to:

- Protect equipment, particularly compressors from expensive damage caused by reverse flow
- Reduce downtime and loss of production due to failure or frequent replacement of unsuitable valves
- Make energy savings as a result of low pressure drop
- Eliminate chatter and reduce the possibility of sudden valve failure in reciprocating compressor applications
- Reduce or eliminate water hammer
- Lower maintenance costs - few moving parts
- Reduce reverse velocity using the fast dynamic response of the Crown-Europa Nozzle Check Valve
- Smaller footprint than conventional check valves with associated dampers/lever
- Flexibility to cope with variable flow conditions
- API 6D end-to-end dimension permits interchangeability with most conventional swing check valves without expensive piping modification

Specifications

Sizes:	End Connections:
<ul style="list-style-type: none"> • 2" - 60" (50mm - 1524mm) 	<ul style="list-style-type: none"> • Flanged end • Hub end • Weld end
<p>Pressure Ratings:</p> <ul style="list-style-type: none"> • Class 150 to 2500 	

Research & Development

Crown-Europa Nozzle Check Valve designs are developed using the latest software-based analysis tools. Using Computational Fluid Dynamics (CFD), a wide range of variations in physical design and operational parameters can be tested and refined until a set which gives optimum performance is identified.

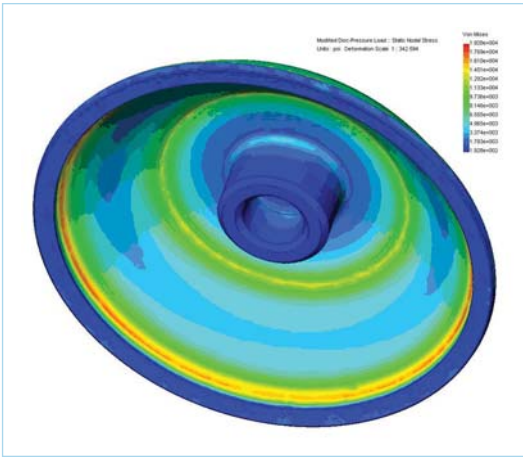

Stress plot for a disc component

Finite Element Analysis (FEA) takes place at the development stage to ensure the design gives the best possible performance. This is achieved by simulating the working conditions of the valve using computational analysis.

At the design stage, cast components are analysed using the latest foundry analysis tools. This vital analysis helps to foresee problems at the casting stages such as problems with feeding and casting quality. It can also help to reduce production costs. Any modifications highlighted from this process can then be fed back into the design before a single pattern has been produced.

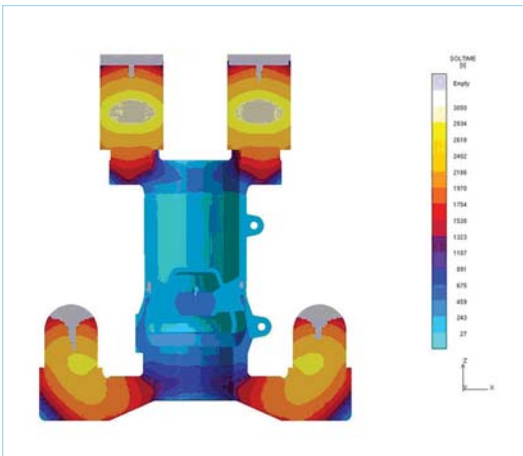

Foundry analysis for a body casting



Founded in 1947, diversification took place in 1990 into the manufacture of valves on behalf of leading valve suppliers to the Oil & Gas Industry. A major investment was required to enable manufacture of valves of the size and rating demanded by the industry and, as a result, Europa Valve now manufacture valves from 2" through 60" with a weight range of 3kg to 10 tons. Valves are available in a wide range of materials ranging from carbon steel to titanium.

The nozzle check valve is a High Integrity Axial Flow Non Slam type suited for severe service and custom built to match service requirements.

Europa Valve is approved to ISO 9001:2000 by Lloyds Register Quality Assurance.

Body Materials:

- Ductile iron
- Carbon steel
- Stainless steel
- Duplex stainless steel
- Low temperature carbon steel

Disc Materials:

- Stainless steel
- Alloy steel
- 11-13 chrome
- Duplex

150 Series

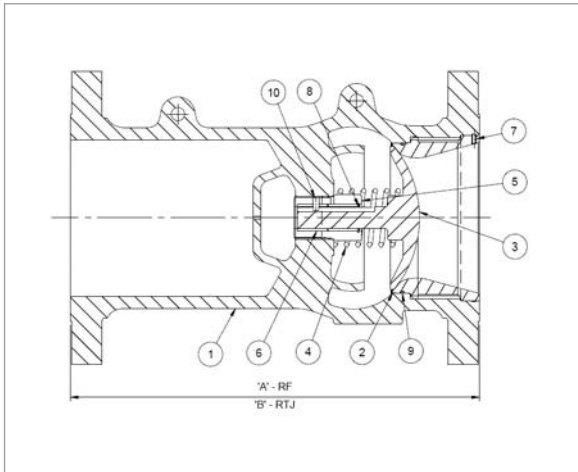

Item	Description	Qty
1	Body	1
2	Seat	1
3	Disc	1
4	Spring	1
5	Guide Housing	1
6	Bushing	2
7	Set Screw	1
8	Retaining Ring	1
9	'O' Ring Seal	1
10	Anti-Rotation Pin	1

Size		Face-to-Face Dimension				Estimated Weight	
		'A' RF		'B' RTJ			
inches	mm	inches	mm	inches	mm	lbs	kg
2	50	8	203	8½	216	22	10
2½	65	8	203	8½	216	26	12
3	80	9½	241	10	254	40	18
4	100	11½	292	12	305	82	37
6	150	14	356	14½	368	101	46
8	200	19½	495	20	508	234	106
10	250	24½	622	25	635	467	212
12	300	27½	699	28	711	728	330
14	350	31	787	31½	800	906	411
16	400	34	864	34½	876	1,468	666
18	450	38½	978	39	991	1,746	792
20	500	38½	978	39	991	1,993	904
24	600	51	1,295	51½	1,308	3,867	1,754
28	700	57	1,448	-	-	5,071	2,300
30	750	60	1,524	-	-	4,202	1,906
32	800	65	1,651	-	-	6,614	3,000
36	900	77	1,956	-	-	8,653	3,925

Short pattern valves, additional valve sizes, pressure ratings and materials are available upon request. The above picture is representative only and may change at the manufacturer's discretion. Due to our policy of continuous improvement, all product information may be subject to change without notice.

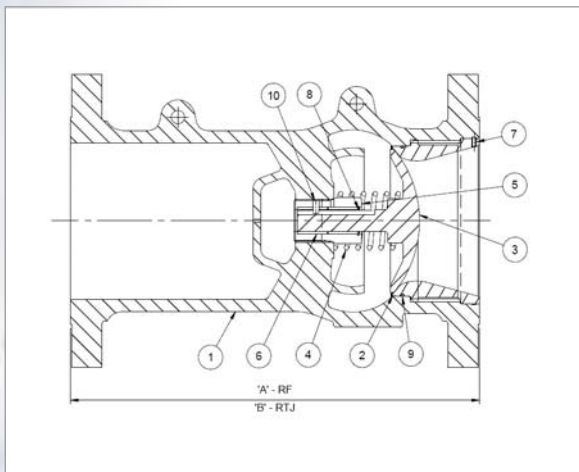

Item	Description	Qty
1	Body	1
2	Seat	1
3	Disc	1
4	Spring	1
5	Guide Housing	1
6	Bushing	2
7	Set Screw	1
8	Retaining Ring	1
9	'O' Ring Seal	1
10	Anti-Rotation Pin	1

Size		Face-to-Face Dimension				Estimated Weight	
		'A' RF		'B' RTJ			
inches	mm	inches	mm	inches	mm	lbs	kg
2	50	10½	267	11⅞	283	29	13
3	80	12½	318	13⅞	333	66	30
4	100	14	356	14⅞	372	106	48
6	150	17½	445	18⅞	460	183	83
8	200	21	533	21⅞	549	293	133
10	250	24½	622	25⅞	638	536	243
12	300	28	711	28⅞	727	820	372
14	350	33	838	33⅞	854	1,124	510
16	400	34	864	34⅞	880	1,605	728
18	450	38½	978	39⅞	994	1,900	862
20	500	40	1,016	40¾	1,035	2,374	1,077
24	600	53	1,346	53⅞	1,368	4,575	2,075
28	700	59	1,499	60	1,524	2,512	2,500
30	750	65	1,524	65½	1,619	4,952	2,246
32	800	70	1,778	71⅞	1,807	7,716	3,500
36	900	82	2,083	83⅞	2,112	9,892	4,487
48	1,200	67⅞	1,711	-	-	-	-

300 Series

Short pattern valves, additional valve sizes, pressure ratings and materials are available upon request. The above picture is representative only and may change at the manufacturer's discretion. Due to our policy of continuous improvement, all product information may be subject to change without notice.

600 Series

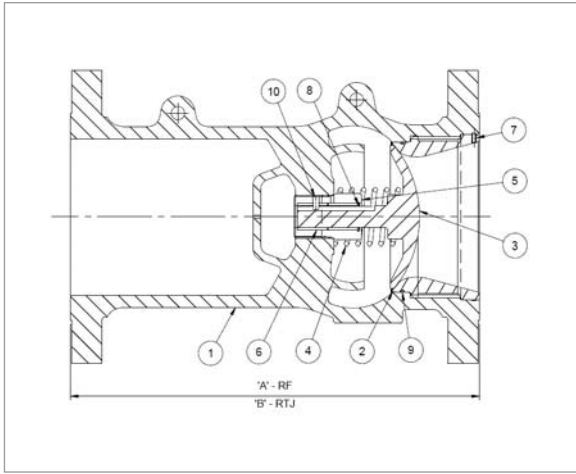

Item	Description	Qty
1	Body	1
2	Seat	1
3	Disc	1
4	Spring	1
5	Guide Housing	1
6	Bushing	2
7	Set Screw	1
8	Retaining Ring	1
9	'O' Ring Seal	1
10	Anti-Rotation Pin	1

Size		Face-to-Face Dimension				Estimated Weight	
		'A' RF		'B' RTJ			
inches	mm	inches	mm	inches	mm	lbs	kg
2	50	11½	292	11⅝	295	33	15
3	80	14	356	14⅞	359	60	27
4	100	17	432	17¼	435	143	65
6	150	22	559	22⅛	562	269	122
8	200	26	660	26⅞	664	463	210
10	250	31	787	31⅞	791	794	360
12	300	33	838	33⅞	841	1,146	520
14	350	35	889	35⅞	892	1,455	660
16	400	39	991	39⅞	994	1,852	840
18	450	43	1,092	43⅞	1,095	2,359	1,070
20	500	47	1,194	47¼	1,200	2,513	1,140
24	600	55	1,397	55⅜	1,407	4,034	1,830
26	650	57	1,448	57½	1,460	5,952	2,700
28	700	63	1,600	63½	1,613	7,165	3,250
30	750	65	1,651	65½	1,661	7,015	3,182
32	800	70	1,778	70⅝	1,794	10,119	4,590
36	900	82	2,083	82⅝	2,099	16,228	7,361
40	1,000	92	2,337	-	-	19,859	9,008
42	1,050	97	2,464	-	-	23,836	10,812
48	1,200	106	2,692	-	-	-	-

Short pattern valves, additional valve sizes, pressure ratings and materials are available upon request. The above picture is representative only and may change at the manufacturer's discretion. Due to our policy of continuous improvement, all product information may be subject to change without notice.

900 Series

Size		Face-to-Face Dimension				Estimated Weight	
		'A' RF		'B' RTJ			
inches	mm	inches	mm	inches	mm	lbs	kg
2	50	14½	368	14⅝	372	71	32
3	80	15	381	15⅛	384	104	47
4	100	18	457	18⅛	460	198	90
6	150	24	610	24⅛	613	397	180
8	200	29	737	29⅛	740	750	340
10	250	33	838	33⅛	841	1036	470
12	300	38	965	38⅛	968	1,631	740
14	350	40½	1,029	40⅞	1,038	2,172	985
16	400	44½	1,130	44⅞	1,140	2,348	1,065
18	450	48	1,219	48½	1,232	3,417	1,550
20	500	52	1,321	52½	1,334	4,608	2,090
24	600	61	1,549	61¾	1,569	6,085	2,760
28	700	70	1,778	70⅞	1,800	10,714	4,860
30	750	75	1,905	75⅞	1,927	12,897	5,850
32	800	82	2,083	82⅞	2,105	15,476	7,020
36	900	90	2,286	91⅛	2,315	21,826	9,900

1500 Series

2	50	14½	368	14⅝	372	71	32.4
3	80	18½	470	18⅝	473	154	47
4	100	21½	546	21⅝	549	243	110
6	150	27¾	705	28	711	551	250
8	200	32¾	832	33⅛	841	1,093	496
10	250	39	991	39⅜	1,000	1,808	820
12	300	44½	1,130	45⅛	1,146	2,976	1,350
14	350	49½	1,257	50¼	1,276	3,880	1,760
16	400	54½	1,384	55⅜	1,470	4,299	1,950
18	450	60½	1,537	61⅜	1,559	5,732	2,600
20	500	65½	1,664	66⅜	1,686	6,592	2,990
24	600	76½	1,943	77⅝	1,972	11,244	5,100

2500 Series

2	50	17¾	451	17⅞	454	104	47
3	80	22¾	578	23	584	238	108
4	100	26½	673	26⅞	683	335	152
6	150	36	914	36½	927	970	440
8	200	40¼	1,022	40⅞	1,038	1,433	650
10	250	50	1,270	50⅞	1,292	2,954	1,340
12	300	56	1,422	56⅞	1,445	3,527	1,600
14	350	49½	1,257	50⅜	1,279	4,784	2,170
16	400	54½	1,384	55⅝	1,412	6,592	2,990

Short pattern valves, additional valve sizes, pressure ratings and materials are available upon request. Due to our policy of continuous improvement, all product information may be subject to change without notice.