

## SMART PRESSURE TRANSMITTER

For Gauge And Absolute Pressure Measurement



### Application Areas:

- Nuclear
- Water & Wastewater
- Chemicals
- Petrochemical
- Oil & Gas
- Pulp & Paper
- Food & Beverage,
- Pharmaceutical
- Power
- Renewable Energy
- Alternate Fuel



**Autrol America Inc,**  
10 N. Martingale Rd, Suite 400.  
Schaumburg, IL 60173. United States  
T: 847-779-5000  
F: 847-655-6062  
Email: [info@autroltransmitters.com](mailto:info@autroltransmitters.com)

## SMART PRESSURE TRANSMITTER



"Autrol America Inc. (AAI) range of transmitters includes a complete range of "intelligent" high performance transmitters for Temperature, Gauge, Absolute, Vacuum & Differential pressure measurements for standalone monitoring and/or closed loop control applications. These "intelligent" microprocessor-based "Smart" transmitters features a two-wire loop powered 4 to 20mA current outputs with "Digital" HART as standard (Foundation Fieldbus optional) communication(s) for seamless integration with a host control system such as DCS, PLC, SCADA, AMS, PDM and/or a local Hand Held Communicator(HHC)."

### Description of Product

The APT3200 series of smart transmitters have excellent stability, high accuracy and include features that facilitate easy installation, start up and minimum maintenance thereby lowering process downtime and overall cost of ownership in the long run.

Autrol transmitters are equipments with analog (4/20mA- 2 wire) and digital (HART or Foundation Fieldbus) communication protocols for seamless integration with a host Control System such as DCS, PLC, SCADA, AMS, PDM and/or Hand Held Communicator (HHC). Through Digital HART Protocol one can easily acquire process measured variable, configure and modify its various Parameters (Range, Tag Name and Damping, Transfer Function, Trimming).

These transmitters are equipped with an automatic temperature compensation function integrated into its advanced signal processing circuitry to ensure high reliability and performance corresponding to change of ambient temperature.

### Features

- Superior Performance
- High Reference Accuracy : $\pm 0.075\%$  of Calibrated Span
- Long-Term Stability
- High Rangeability ( 100 : 1 )
- Flexibility
- Data Configuration with HART Configurator
- Zero Point Adjustment
- Reliability
- Continuous Self-Diagnostic Function
- Automatic Ambient Temperature Compensation
- Fail-mode Process Function
- EEPROM Write Protection
- CE EMC Conformity Standards(EN5081-2, EN50082-2)



### Function

- Flexible Sensor Input : GP, AP, Vacuum
- Various Output : 4 ~20mA , Digital Signals
- Setting Various Parameters : Zero/Span, Trim, Unit, Fail-mode, etc
- Self Diagnostic Function : Sensor, Memory
- A/D Converter, Power, etc
- Digital Communication with HART protocol
- Explosion-proof Approval & Intrinsic Safety Approval : KOSHA, KTL, CSA,FM, ATEX

## SMART PRESSURE TRANSMITTER



### TRUE SMART

The heart of Autrol smart transmitter is a microprocessor-based high performance module. In addition, each transmitter is ambient temperature characterized using state-of-art technologies to ensure maximum transmitter accuracy and minimized drift over a wide range of operating temperatures.

On integrated sensor models such as in APT3200 series transmitters the characteristics data of its sensor are stored in internal non-volatile EEPROM to minimize measuring error. On non sensor transmitter models such as ATT2100 temperature transmitters, it has a linearization table built in wherein user can modify the various necessary values in field per the added temperature sensor (RTD or T/C) characteristics to get better accuracy from the overall measurement system. Its integral microprocessor module then automatically converts the required value referring to the customized linearization table.

All transmitters include advanced self diagnostic functions for detecting any malfunctions of sensor and/or fault of A/D converter, internal memory and microprocessor. All diagnostic/error status is transmitted to a connected Master by analog current signal (fail mode current 3.75mA or 22mA) or digital HART (or FF) communication.

The transmitters have Last Value Status (L V S) function for safety of instrumentation. When the sensor input occurs in abnormal status, output is fixed to the previous value and when the recovery to normal status, output is updated to the current value. If abnormal status of sensor is being continued during the defined interval, the fault is recognized as a sensor failure & reported accordingly for corrective action.

### OPEN ARCHITECTURE

Using a Device Master (AMS, PMD etc) or a hand-held terminal, PC configuration program or HART Compatible DCS, PLC or SCADA the user can change, modify and review parameters of smart transmitter through HART communication. There functions provide convenience for your calibration and maintenance practice.



### FIELD PROGRAMMABLE

All Autrol transmitter have a fully programmable front panel from which users can directly input values ( e.g. range, zero/span, sensor type, thermocouples, RTD and mV and automatic temperature compensation) to reduce cost of installation and commissioning eliminating need of a additional configuration tools.

**Stable Measurable Accurate Reliable Transmitters**

## SMART PRESSURE TRANSMITTER

### Electronics Module

The Electronics module consists of a circuit board sealed in an enclosure. There is a MCU module, a power module, an analog module, a LCD module and a terminal module included within the transmitter.

The MCU modules acquire the digital value from the analog module and apply correction coefficients selected from EEPROM. The output section of the power module converts the digital signal to a 4~20 mA output. The MCU module communicates with the HART-based Configurator or Control Systems such as DCS. The Power modules have a DC-to-DC Power conversion circuit and an Input/output isolation circuit. An optional LCD module plugs into the MCU module and displays the digital output in user-configured unit.

### Sensor Inputs

The model APT3200 is available in an absolute pressure sensor of a piezo-resistive type and measures absolute pressure.

The sensor module converts the capacitance or the resistance to the digital value. The MCU module calculates the process pressure based on the digital value.

The sensor modules include the following features

- +/-0.075% accuracy, the most accurate sensor in the industry.
- The software of the transmitter compensates for the thermal effects, improving performance.
- Precise Input Compensation during operation is achieved with temperature and pressure correction coefficients that are characterized over the range the transmitter and stored in the sensor module EEPROM memory.

- EEPROM stores sensor information and correction coefficients separately from MCU module, allowing for easy repair, reconfiguration and replacement

### Basic Setup

APT3200 Pressure transmitter can be easily configured from any host that supports the HART protocol.

- Operational Parameters
- Operational Parameters.
- 4~20mA Points (Zero/Span)
- Engineering Units
- Damping Time: 0.25 ~ 60 sec
- Tag: 8 alphanumeric characters
- Descriptor: 16 characters
- Message: 32 characters.
- Date: day/month/year

### Calibration and Trimming

- Lower/Upper Range (zero/span)
- Sensor Zero Trimming
- Zero Point Adjustment
- DAC Output Trimming
- Transfer Function
- Self-Compensation

### Self-Diagnosis and Others

- CPU & Analog Module Fault Detection
- Communication Error
- Fail-mode Handling
- LCD Indication
- Temperature Measurement of Sensor Module

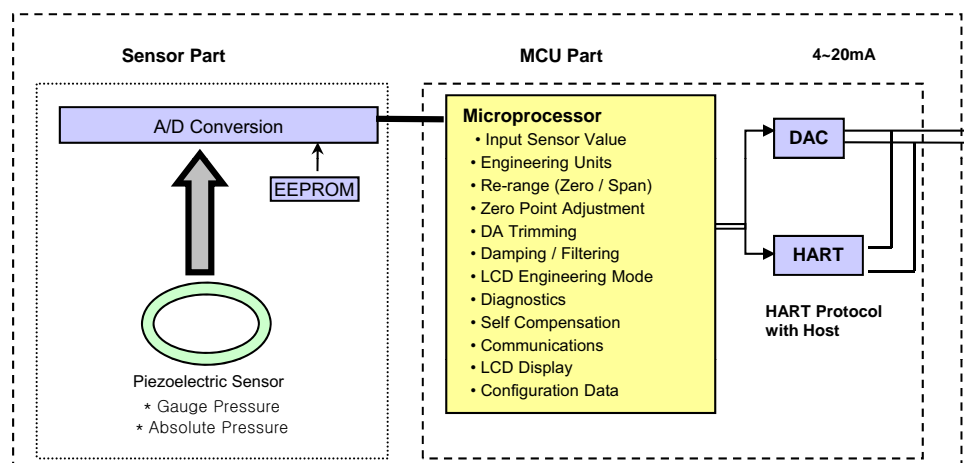

## SMART PRESSURE TRANSMITTER

### Range and Sensor Limits

Refer to Table 1

### Zero and Span Adjustment Limits

- Zero and span values can be set anywhere within the range limits stated in Table 1.
- Span must be greater than or equal to the minimum span stated in Table 1

### Output (Analog Current and Digital Data)

- Two wire 4~20mA user-configurable for linear output, digital process value superimposed on 4~20mA signal, available to any host that conforms to the HART protocol

### Power Supply & Load Requirement •

- **External power supply required**  
Transmitters operate on 11.9 to 45 V dc.  
\* 250 ohm load-- 17.4 Vdc  
\* Up to a 550 ohm load -- 24 Vdc  
Max. Loop Resistance =  $(E - 11.9)/0.022$   
(E = Power Supply Voltage)
- **Supply Voltage**  
11.9 ~ 45 Vdc -- operation  
17.4 ~ 45 Vdc -- HART Communications  
11.9 ~ 42 Vdc -- CSA Approval
- **Loop Load**  
0 ~ 1500 ohm – Operation  
250 ~ 550 ohm -- HART Communications

### EMC Conformity Standards

- EMI (Emission) – EN50081-2:1993
- EMS (Immunity) – EN50082-2:1995

### Update Time and Turn-On Time

- Update Time : 0.12 seconds
- Turn-On Time : 3 seconds

### Failure Mode

- Fail High : Current  $\geq 21.1$  mA
- Fail Low : Current  $\leq 3.78$  mA

### Storage Temperature

- $-40^{\circ}$  C to  $85^{\circ}$  C (without condensing)

### Process Temperature Limits

(Range codes and approval codes may affect limits)

- $-40^{\circ}$  C to  $120^{\circ}$  C (  $-40$  to  $248^{\circ}$  F )

### Isolation

- Input/output isolated to 500Vrms (707 Vdc)

### Overpressure Limits (silicone oil)

Overpressure Limits (silicone oil)

Model G	-100 ~ 400 KPa	----- # 3
	-100 ~ 4000 KPa	----- # 4
	0 ~ 14,000 KPa	----- # 5
	0 ~ 70,000 KPa	----- # 6
	0 ~ 80,000 KPa	----- # 7
Model A	0 ~ 700 KPa	----- # 4
	0 ~ 4000 KPa	----- # 5
	0 ~ 7000 KPa	----- # 6

### Physical Specifications

#### Wetted Materials

- Isolating Diaphragms ----316L SST, Monel, Tantalum, HAST-C

#### Non-wetted materials

- Fill Fluid -----Silicone oil
- Electronics Housing ---Aluminum, Flameproof and Waterproof (IP67)
- Cover O-ring -----Buna-N
- Paint -----Epoxy-Polyester or Polyurethane
- Mounting Bracket -----2-inch Pipe, 304 SST, Painted Carbon Steel  
with  
304 SST U-bolt
- Nameplate -----304 SST

#### Electrical connections

- 1/2-14 NPT conduit with M4 Screw Terminals

#### Process Connections

- 1/2-14 NPT Female
- 1/4-18 NPT (option)

#### Weight

- 1.7 kg (excluding options)

## SMART PRESSURE TRANSMITTER

### Hazardous Location Certifications (option)

**KOSHA Approvals** (KOSHA: Korea Occupational Safety & Health Agency)

**K1 Code:**

Flameproof for Class I, Zone 1: Ex d IIC T6, IP67  
Ambient Temperature: -20 to 60 °C  
Max. Process Temperature: 80 °C  
Power Supply: Max. 45 Vdc  
Output: 4 to 20 mA + HART, Max. 22 mA

**KTL Certification** (KTL: Korea Testing Laboratory)

**K2 Code:**

Intrinsic Safety: Ex ia IIC T5  
Ambient Temperature: -20 to 60 °C  
Max. Process Temperature: Max. 100 °C  
Entity Parameter: Umax=40Vdc, Imax=165mA,  
Pmax = 0.9W

**CSA** (Canadian Standards Association) Approvals

**C1 Code:**

“SEAL NOT REQUIRED”

Explosion proof for Class I, Division 1,  
Groups A, B, C & D  
Dust-ignition proof for Class II, Division 1,  
Groups E, F & G; Class III  
Flameproof for Class I, Zone 1: Ex d IIC  
“T6, See Instruction for temperature code if  
process temperature above 85 °C”  
Class I, Division 2, Groups A, B, C, D;  
Class II, Division 2, Groups E, F, G;  
Class III T4  
Non sparking Equipment for Class I Zone 2:  
Ex nA IIC T4  
Enclosure: Type 4x, IP66  
Power Supply: 11.9 to 42 Vdc Max.  
Output Signal: 4 to 20 mA + HART

**FM** (Factory Mutual explosion proof) Approvals

**F1 Code:**

Explosion proof for Class I, Division 1  
Groups A, B, C and D  
Dust-ignition proof for Class II, Division 1,  
Groups E, F and G  
Dust-ignition proof for Class II, Division 1  
“T6, see instruction for temperature code if  
Process temperature above 85°C”  
Ambient Temperature: -20 to 60°C  
Enclosure: indoors and outdoors, NEMA Type 4X  
Conduit seal required within 18” for Group A only.  
Nonincendive for Class I, Division 2, Groups A, B,  
C & D  
Class II, Division 2, Groups E, F & G; and Class  
III, Division 1,  
Temperature Code T4  
Ambient Temperature: -20 to 60°C  
Enclosure: indoors and outdoors, NEMA Type 4X

**ATEX Approvals**

**E1 Code:**

ATEX Certificate number: KEMA07ATEX0103  
CE0344  II 2 G  
Ex d IIC T6 or T5

Operating Temperature: -20°C ≤ Tamb ≤ +60°C  
T6 for process < 85°C; T5 for process < 100°C

*\* If you need to order the model with the certificate of CSA, FM and ATEX, Please contact the manufacturer before order.*

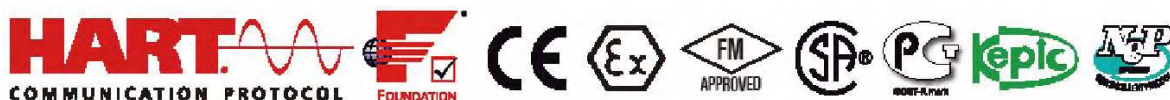

## SMART PRESSURE TRANSMITTER

### General Specifications

#### 1) APT3200 –G/A Pressure Sensor Range (Rangeability = 100 : 1)

Table 1

	APT3200 – G		APT3200 - A	
	Range (KPa)	Calibrated Span (KPa)	Range (KPa)	Calibrated Span (KPa)
3	-100 ~ 150	1.5 ~ 150	NA	NA
4	-100 ~ 1,500	15 ~ 1,500	0 ~ 250	2.5 ~ 250
5	0 ~ 5,000	50 ~ 5,000	0 ~ 1,500	15 ~ 1,500
6	0 ~ 25,000	250 ~ 25,000	0 ~ 2,500	25 ~ 2,500
7	0 ~ 60,000	600 ~ 60,000	NA	NA

#### 2)Electrical Specifications

Power Supply	11.9 ~ 45 Vdc	Output Signal	4 ~ 20 mA dc/HART
HART loop resistance	250 ~ 550 ohm	Isolation	500 Vrms (707 Vdc)

#### 3)Performance Specifications

Reference Accuracy	$APT3200 - G/APT 3200 - A$ $\pm 0.075\%$ of Span ( $0.1URL \leq Span \leq URL$ ) $\pm [0.025 + 0.005 \times (URL/Span)]\%$ of Span ( $0.01URL \leq Span < 0.1URL$ )	Ambient Temperature	-40°C ~ +85°C
		LCD Meter Ambient Temp.	-30°C ~ +80 °C
		Humidity Limits	5% ~ 98% RH
Ambient Temperature Effect	$APT3200 - G/APT 3200 - A$ $\pm [0.019\%URL + 0.125\% Span] / 28^\circ C$	Process Temperature Limits	-30°C ~ +100°C
		Power Supply Effects	$\pm 0.005\%$ of Span per Volt
		Stability	$APT3200-G/APT3200 - A$ $\pm 0.125\%URL$ for 12 months

#### 4)Physical Specifications

Isolating Diaphragm	316L SST	Process Connection Size	1/2 – 14 NPT Female
Electronic Housing	Aluminum(Option: SST)	Electrical Connections	1/2 – 14 NPT with M4
Housing Class	Waterproof (IP67)	2" Pipe Stanchion Type bracket	Angle or Flat type
		Weight (excluding Option Items)	1.7 Kg

#### 5)Hazardous Location Certifications (option)

Available Approval
Flameproof Approval : Ex d IIC T6 (KOSHA) Intrinsic Safety Approval : Ex ia IIC T5 (KTL) CSA (Canadian Standards Association) FM Explosion proof approval ATEX Flame proof Approval

## SMART PRESSURE TRANSMITTER

### Ordering Information

Model	Code	Description					
APT3200	-G	Gauge Pressure Transmitter (reference accuracy : 0.075 % of span )					
	-A	Absolute Pressure Transmitter (reference accuracy : 0.075 % of span )					
Range		G			A		
		Range(KPa)	Min. Span (KPa)	Range (Kpa)	Min. Span (KPa)		
	3	-100 ~ 150	1.5	NA	NA		
	4	-100 ~ 1,500	15	0 ~ 250	2.5		
	5	0 ~ 5,000	50	0 ~ 1,500	15		
	6	0 ~ 25,000	250	0 ~ 2,500	25		
	7	0 ~ 60,000	600	NA	NA		
X	Special						
Mounting Flange Size Material		DIAPHRAGM			OTHER		
	M11	316 SST			316 SST		
	M12	HAST-C			316 SST		
	M13	Tantulam			316 SST		
	M21	HAST-C			HAST-C		
Hazardous Location Certificates	K0	Maker Standard (Waterproof : IP67 )	*E1	ATEX(KEMA) Flameproof			
	K1	KOSHA Flameproof Approval : Ex d IIC T6	*E2	ATEX(KEMA) Intrinsic Safety			
	K2	KTL Intrinsic Safety Approval : Ex ia IIC T5	F1	FM/FMC Explosion proof (for USA & Canada)			
	*F2	FM Intrinsic Safety					
Fill Fluid	1	Silicone					
	*2	Inert fill Fluid (Halocarbon Oil)					
Process Connection	S	1/2 – 1/4 NPT Female (Standard)	O	1/4 - 18 NPT Female Adapter)	X	Special	
Electrical Connection	1	1/2-14NPT	*2	G1/2	X	Special	
Option	M1	LCD Indicator(5digit)					
	LP	Lighting Protector (Internal Type)					
	K	Oil Free Finish					
	2W	2 Way Manifold Flange Type (Add Remark "Remote Type")					
	BA	Stainless Steel Bracket (Angle type) with SST Bolts					
	BF	Stainless Steel Bracket (Flat type) with SST Bolts					
	ST	Stainless Steel (SUS 316) Housing					

**Example: APT3200-G5-M11-K0-1-S-1-M1**

Note 1: Request manufacturer for Draft Range, Absolute (small pressure and vacuum) and Items marked "\*" before order.

## SMART PRESSURE TRANSMITTER

### Connection Diagram of Signal, Power, HHT for Transmitter

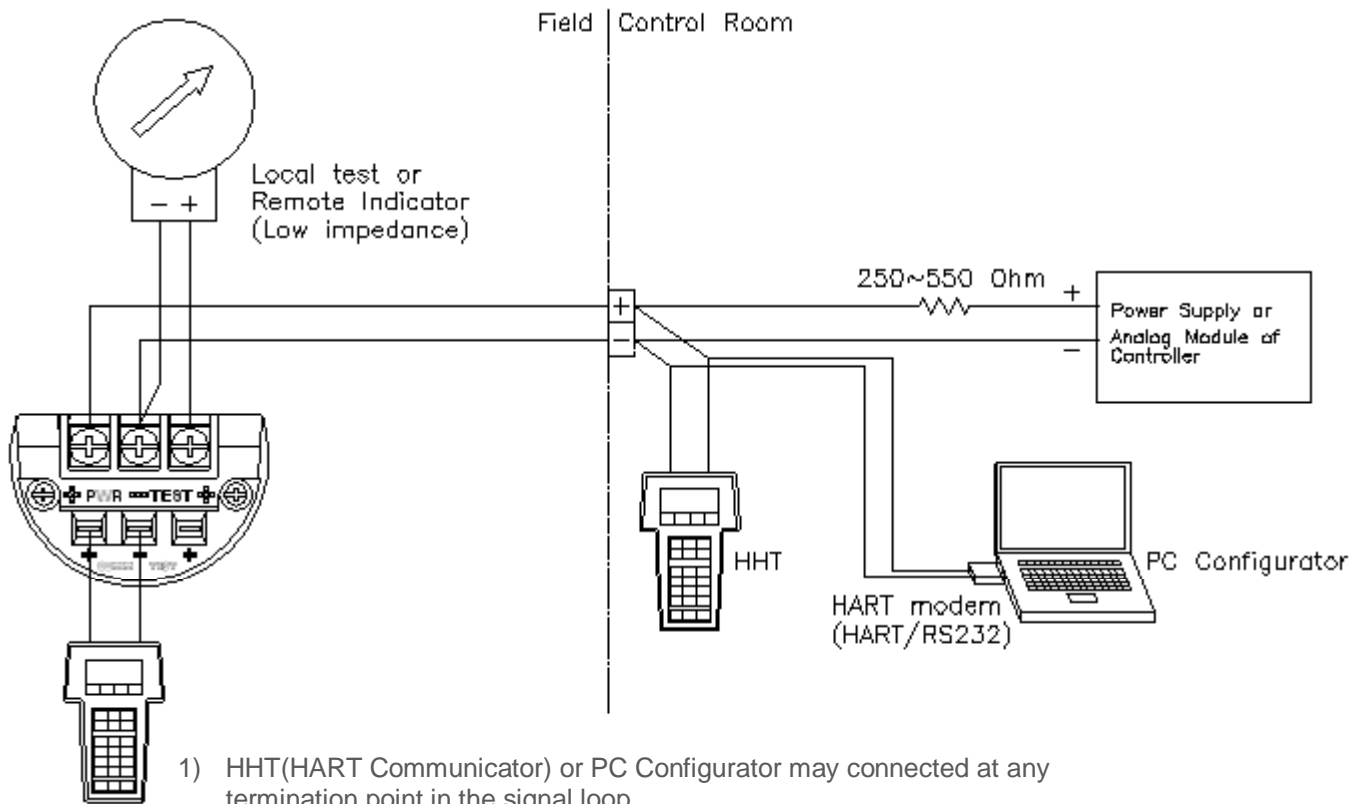

- 1) HHT(HART Communicator) or PC Configurator may connected at any termination point in the signal loop
- 2) HART Communication requires a loop resistance between 250 and 550 ohm @ 24 Vdc
- 3) Transmitter operates on 11.9 to 45.0 Vdc transmitter terminal voltage.  
 [Applied Power]
  - \* 11.9 ~ 45.0 Vdc for General Operation
  - \* 17.4 ~ 45.0 Vdc for HART Communication
  - \* 17.4 ~ 42.0 Vdc for CSA Approval (Power supply must not exceed 42.0 Vdc)

## SMART PRESSURE TRANSMITTER

### Dimensions of Transmitter (mm)

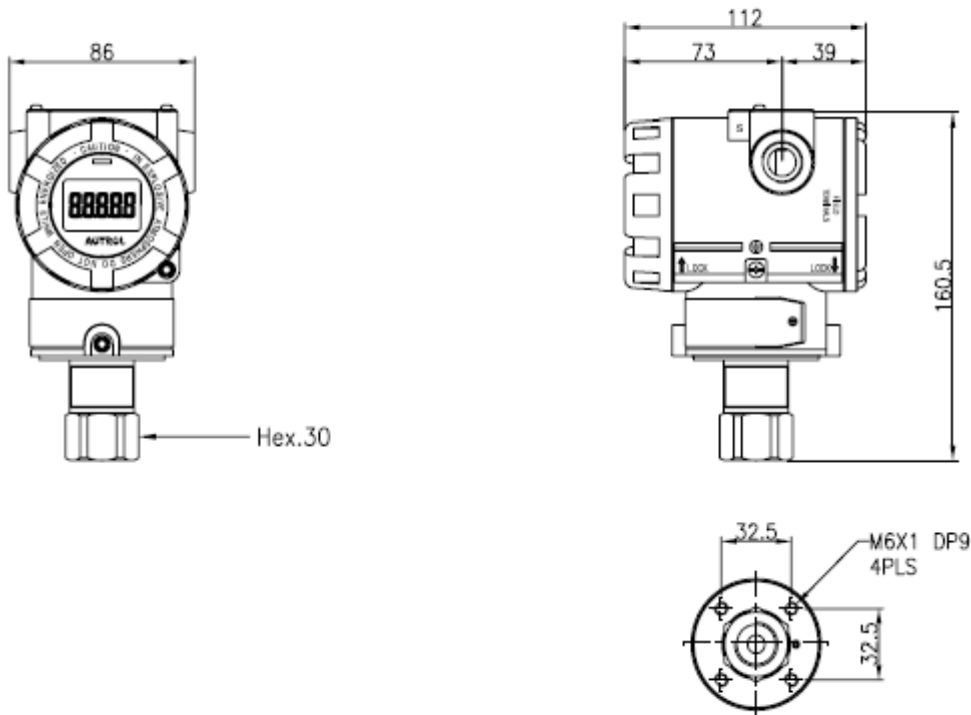

**Autrol America Inc,**  
 10 N. Martingale Rd, Suite 400. Schaumburg, IL 60173.  
 United States T: 847-779-5000 | F: 847-655-6062 |  
 Website: [www.autroltransmitters.com](http://www.autroltransmitters.com)  
 Email: [info@autroltransmitters.com](mailto:info@autroltransmitters.com)